

SA basics

Introduction - spectrum

- time domain signal can be transformed into its frequency domain equivalent – spectrum:
 - collection of sine waves of given frequency, amplitude and phase which, when combined properly, produce the time-domain signal under examination

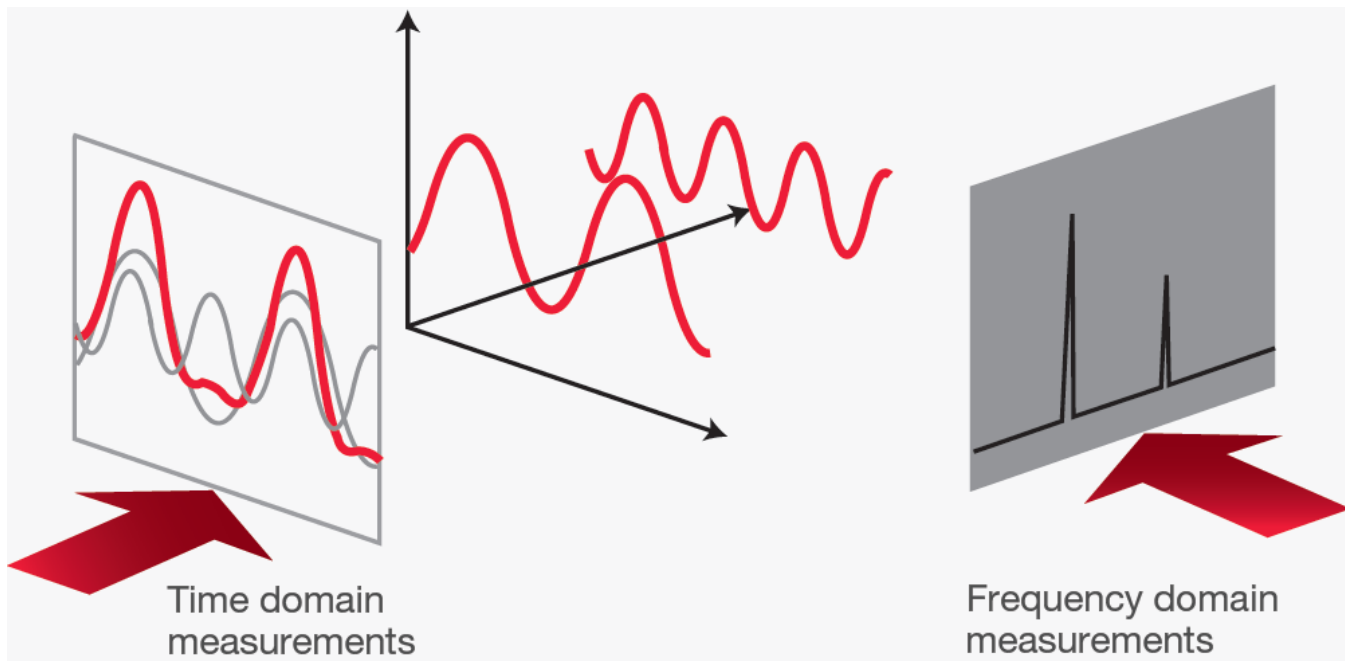

Introduction - spectrum

- spectrum measurements are very important in the RF area:
 - Tx/Rx design and testing – spectral content of the signals
 - harmonics, intermodulation products, spurious signals, signal distortion
 - spectrum monitoring, coexistence of different communication standards, EMC, ...
- traditional spectrum analyzers show only the frequency and amplitude of the measured signals
 - sufficient in most cases
- modern signal analyzers preserve also the phase information
 - can be used to analyze signals using complex digital modulations

Introduction – spectrum analyzer

- „a frequency selective, peak-responding voltmeter calibrated to display the rms value of a sine wave“
 - the spectrum analyzer is not a power meter, even though it can be used to display power directly
 - in some cases, the readings can be misleading when interpreted incorrectly
- different types of spectrum analyzers:
 - swept-tuned superheterodyne analyzers – display only frequency/amplitude information
 - signal analyzers – SA + analysis of complex modulated signals
 - real time spectrum analyzers (RTSA)

swept SA - block diagram

- basic block diagram of an analog swept spectrum analyzer:

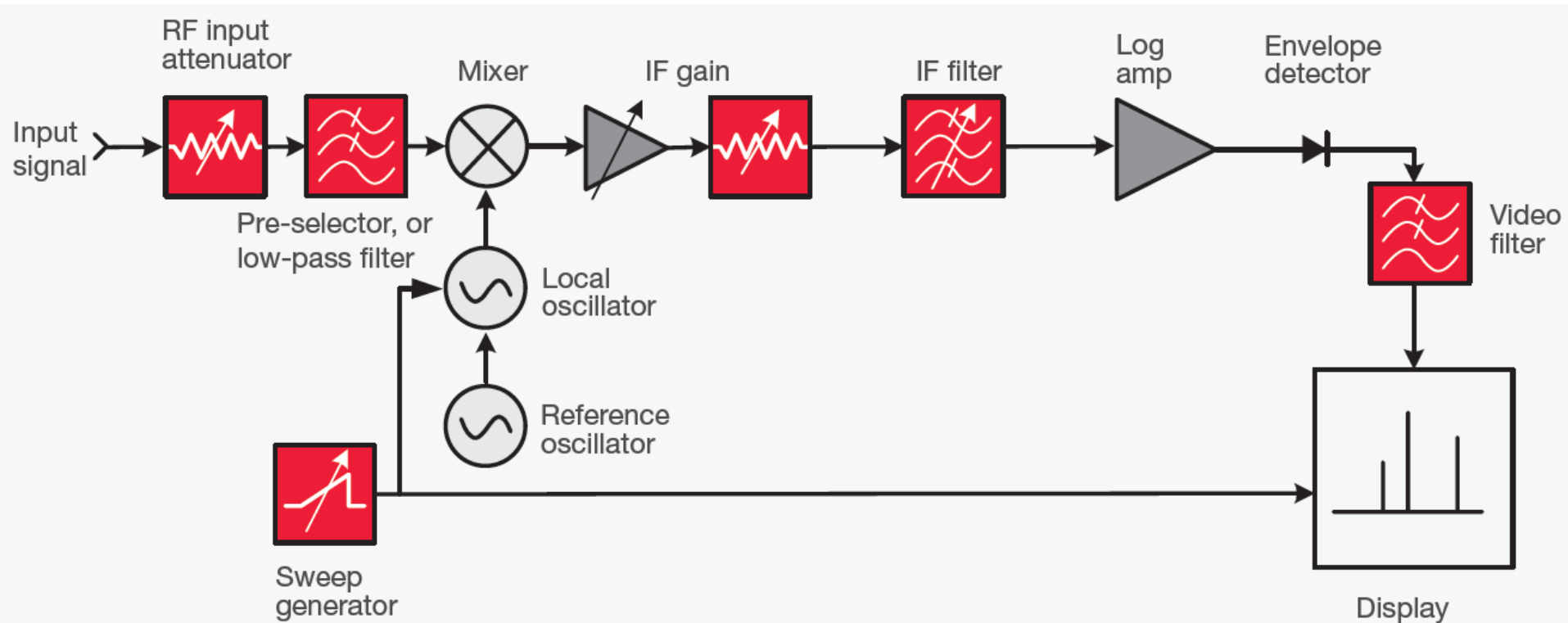

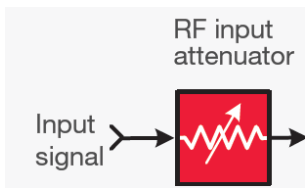

Input attenuation

- the first part of the SA is the RF input attenuator
- it ensures that the signal enters the mixer at the optimum level to prevent overload, gain compression and distortion
- it also serves as a protective circuit for the analyzer
- by default, it is set automatically based on the ref. level
 - can be set manually in the whole range from 0 dB up if needed
 - different instruments offer different step size (10, 5, 2, 1 dB)

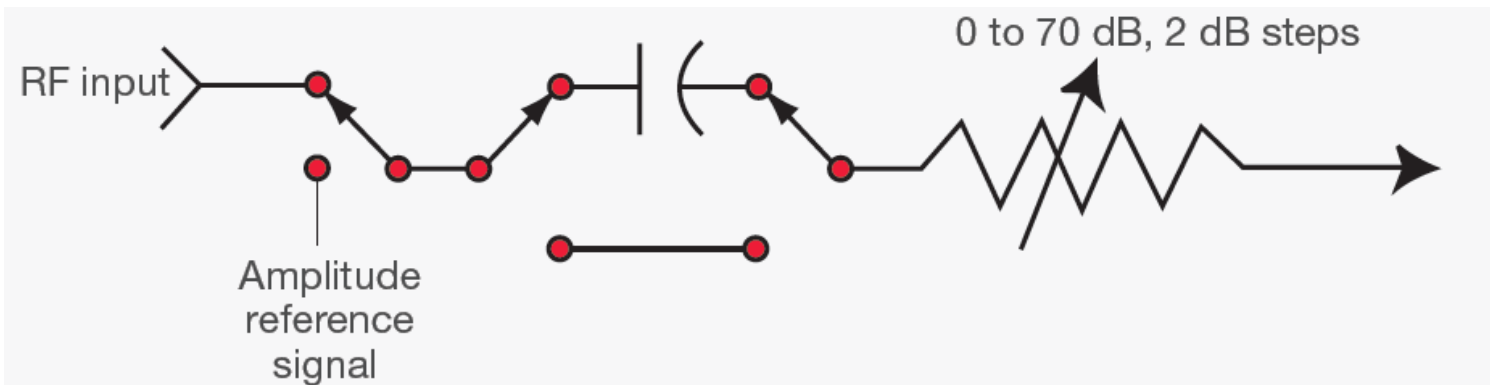

Input attenuation

- the input attenuator has a direct influence on the displayed average noise level (DANL)
 - 1 dB increase of attenuation will increase the noise level by 1 dB
 - for best possible sensitivity, set the attenuator manually to 0 dB
- after the attenuator, there is a filter which blocks out-of-band signals from reaching the mixer
 - these signals could mix with the local oscillator signal and create unwanted responses on the display
 - fixed low pass filter (in lower frequency SAs)...
 - ... or a tunable preselector on high-frequency instruments

Input filtering

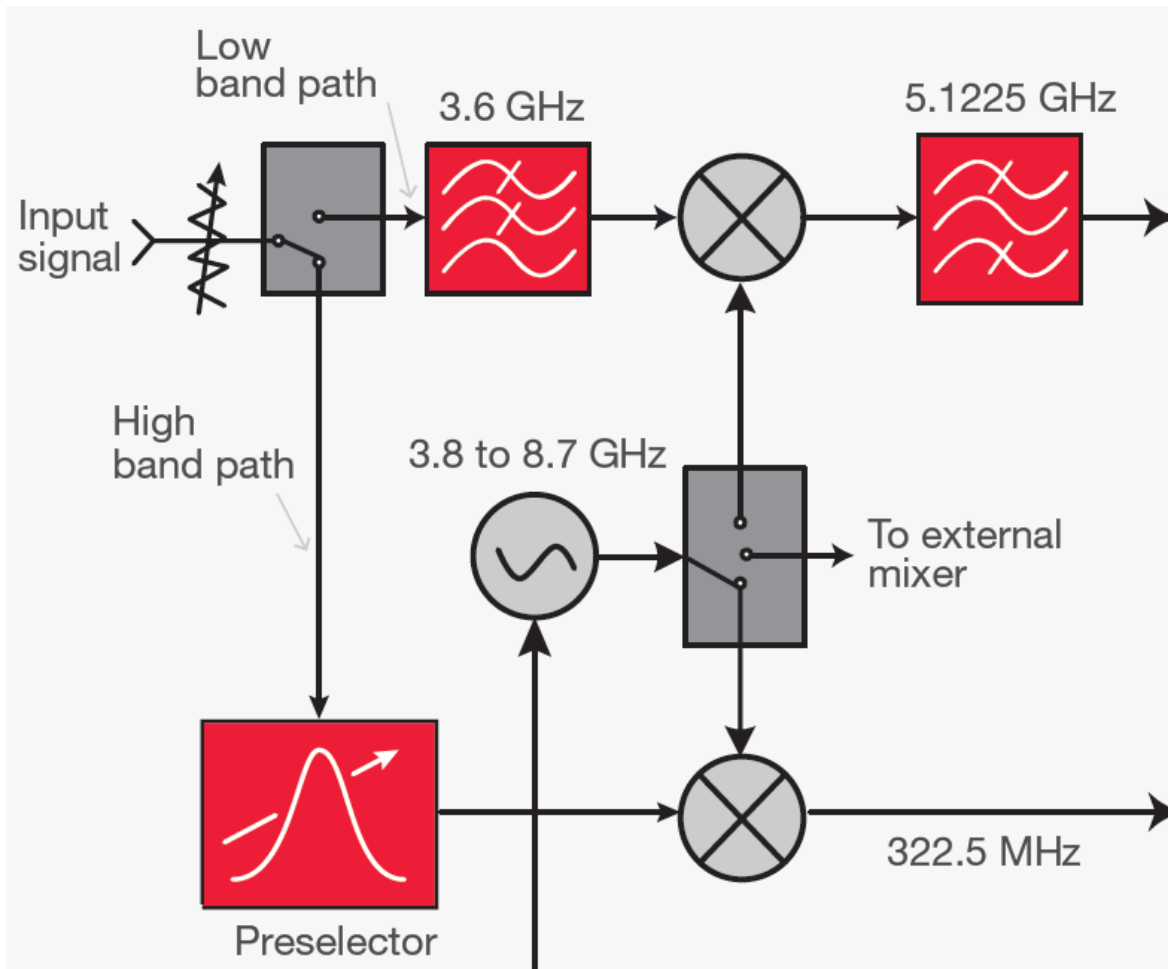

Tuning the SA – input mixer

- there are typically multiple mixer stages (because narrow IF filters would be difficult to achieve at high center frequencies)

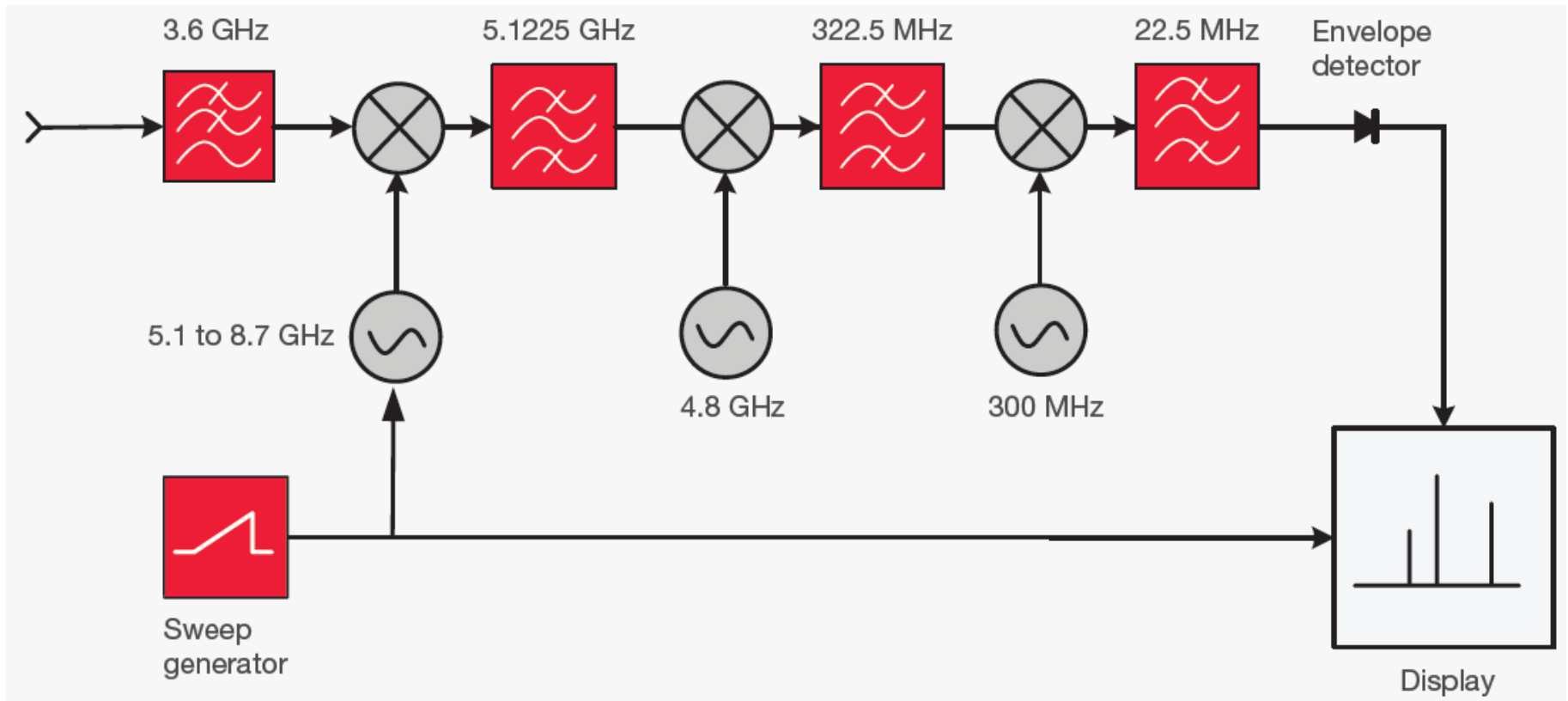

Resolving signals - RBW

- after the IF amplifier, there is the IF section consisting of a bank of resolution bandwidth (RBW) filters – analog or digital (modern SAs use only digital filters)
 - typically from 1 Hz to 10 MHz of bandwidth
 - the mixing products are swept across these filters
 - a single harmonic signal will draw the characteristic shape of the bandpass filter on the display:

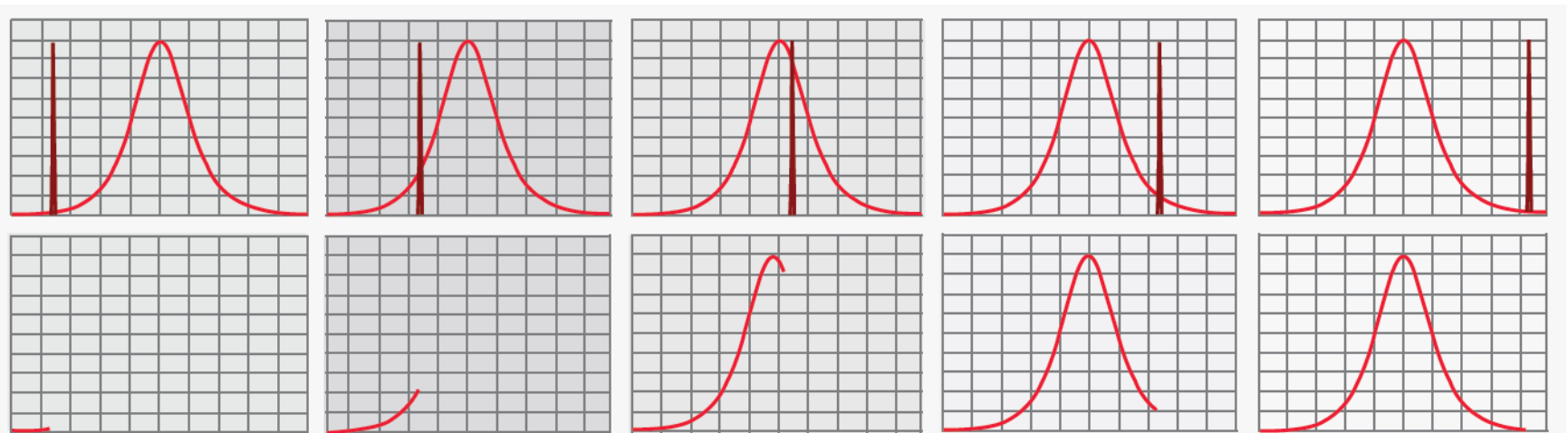

RBW

- the width of the RBW filter will define the ability of the SA to resolve nearby individual harmonic components

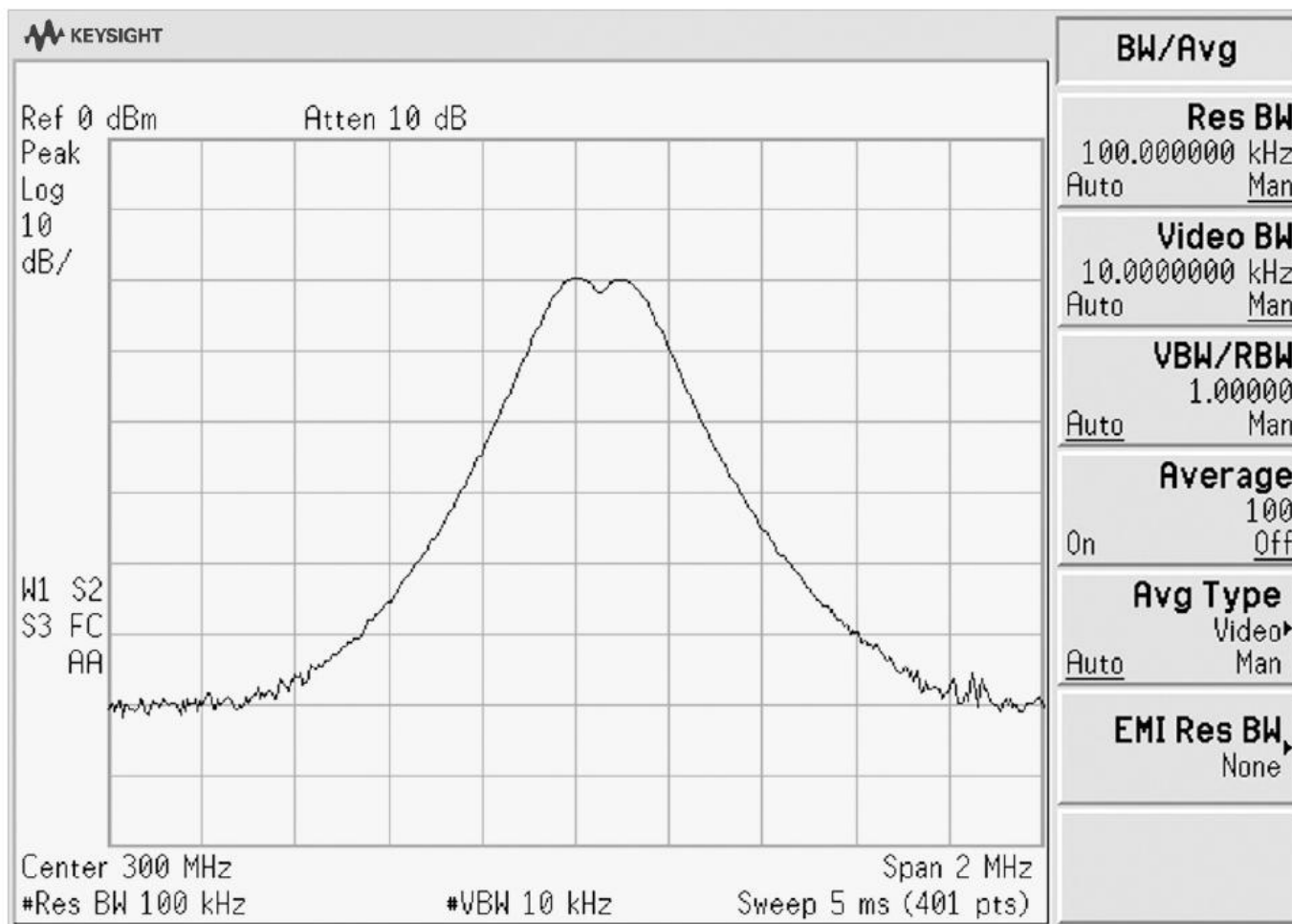

RBW vs. Sweep time

- the RBW IF filters are band-limited circuits that require finite times to charge and discharge
 - if the mixing products are swept through them too quickly, there will be a loss of displayed amplitude and a false frequency shift
 - for the traditional analog IF filters, the required sweep time was inversely proportional to the IF (RBW) bandwidth
 - this is why it is not possible to always choose the lowest available RBW; RBW selection is a compromise between speed and resolution
 - modern SAs with digital RBW filters use multiple techniques to speed up the measurement even with narrow RBWs

RBW vs. Sweep time

- example of the amplitude and frequency shift perceived when a shorter than optimum sweep time is selected:

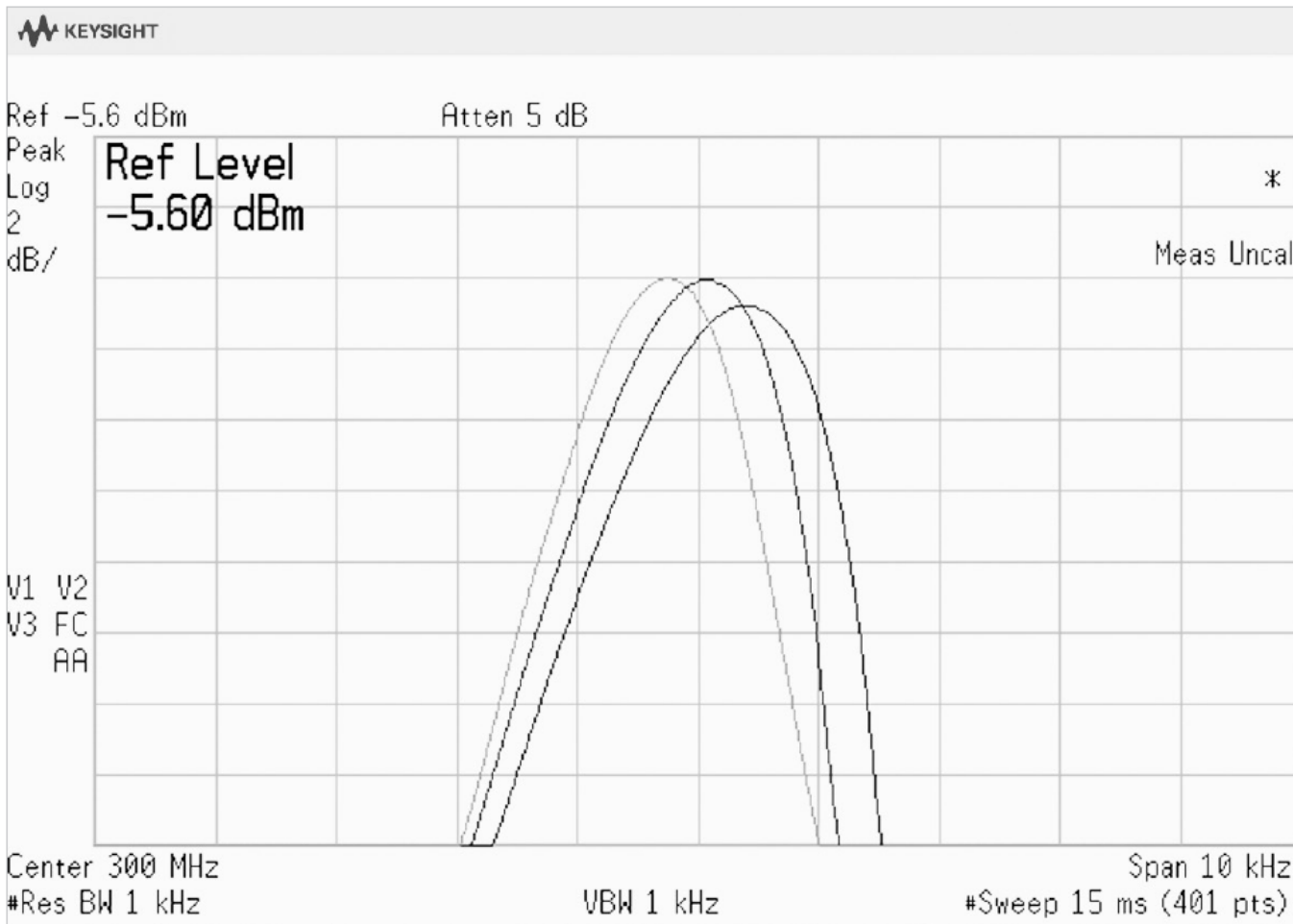

RBW vs. DANL

- the broadband thermal noise is always measured along with the signals of interest
 - wider RBW filter integrates more of this noise; the power of the noise is proportional to the IF bandwidth
 - 10 times increase in RBW will mean 10 times the measured noise power and 10 dB higher DANL
 - it is necessary to choose narrow enough RBW to be able to see signals close to the noise floor
 - RBW selection will be a compromise between measurement speed (sweep time) and the DANL

Envelope detector

- older analyzers typically converted the IF signal to video with an envelope detector – simplest one consists of a diode, resistive load and low-pass filter
 - it follows the amplitude envelope of the IF signal
 - the detector must be able to follow the changes in the envelope created by the signals within the RBW but not the 22.5 MHz IF signal

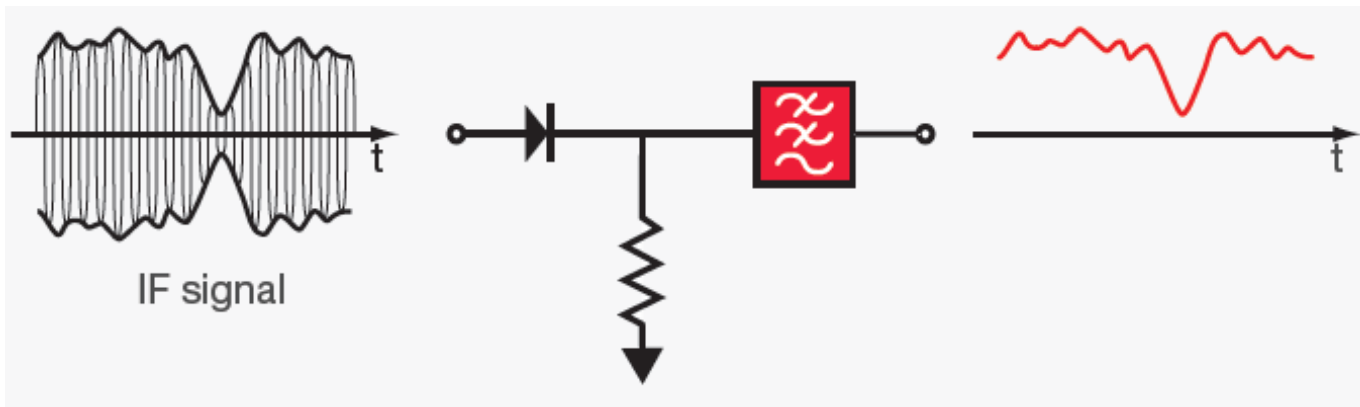

Envelope detector

- the envelope detector is what makes the SA a voltmeter
 - for example, if there would be two equal-amplitude signals present in the pass band of the IF at the same time:
 - power meter would indicate a power level 3 dB above either signal (twice the power of individual harmonic signals)
 - the SA display will vary between a value that is twice the voltage of either signal (6 dB greater) and zero (minus infinity on the log scale)

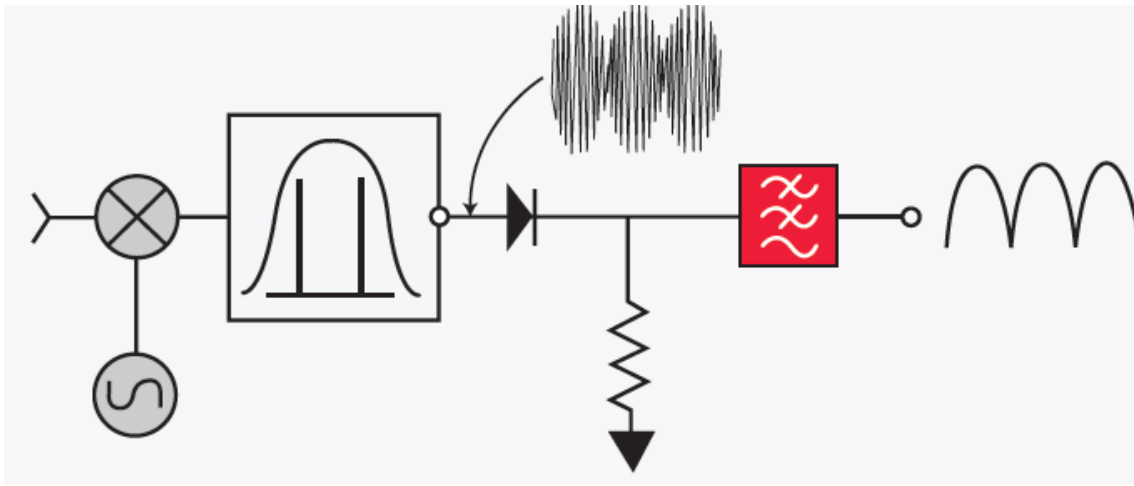

Display

- the display is mapped on a grid (graticule) with 10 horizontal divisions and usually 10 vertical divisions
 - the horizontal axis is linearly calibrated in frequency (left → right)
 - frequency range is typically set in two steps – center and span
 - alternatively, it is possible to define the start and stop frequencies
 - the vertical axis is calibrated in amplitude – linear (V) or log (dB)
 - the logarithmic scale is used more often because it can display much wider amplitude range (typically 10 dB/div → 100 dB range)
 - the linear scale is usable for signals differing by no more than 20 to 30 dB (voltage ratios of 10 to 32)
 - scale calibration, both frequency and amplitude, is shown by annotations written onto the display

Display detector types

- modern digital spectrum analyzers have a limited display resolution and settable number of trace points
- each data point represents certain frequency span which can be relatively wide for example for a full band scan
 - $3 \text{ GHz} / 1001 \text{ points} = 3 \text{ MHz/point}$
 - within this span (called „bucket“), the SA will make a larger number of measurements (depending on the bucket span and sweep time)
 - because of this, it is necessary to decide what value should be displayed for each trace data point
 - for this purpose, it is possible to choose from different „display detectors“ – Sample, Positive/Negative Peak, Normal, Average, Quasipeak

Display detector types

- Sample and Positive/Negative Peak detectors:

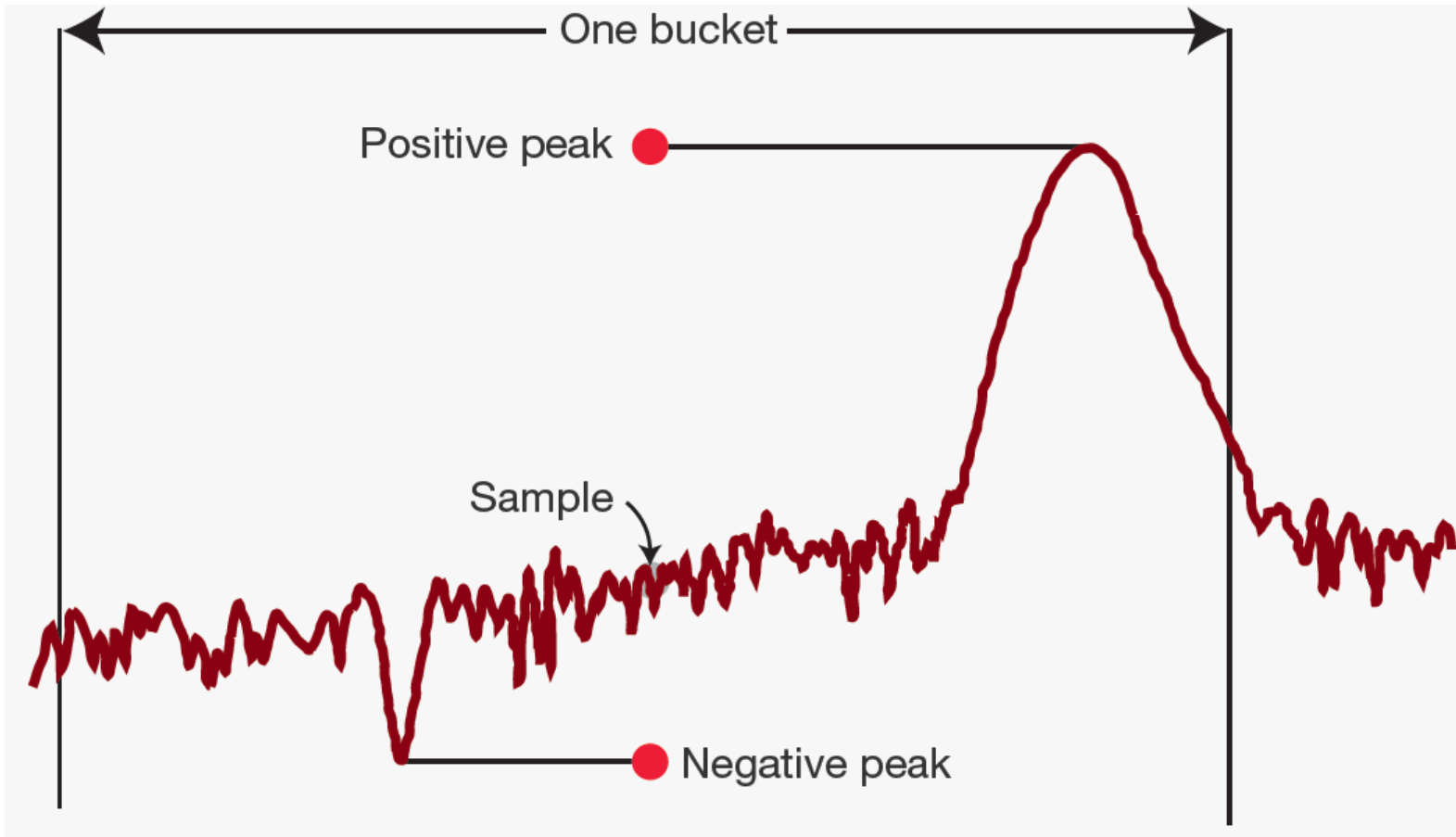

Display detector types

- Sample detector
 - this detection method selects the data point as the instantaneous level at the center of each bucket
 - it is best at indicating the randomness of noise, but not good for analyzing sinusoidal signals
 - in case the RBW is narrower than the bucket span, the sample detector will report the right amplitude of the signal only if it falls at the center of the frequency interval

Display detector types

- Positive peak detector
 - selects the maximum amplitude value encountered in each bucket
 - this detection mode ensures that the true amplitude of sinusoidal signals will be displayed and that no signals will be missed
 - (because of the detection method; otherwise, swept spectrum analyzers may miss many intermittent signals because they are measuring elsewhere)
 - on the other hand, this mode does not give a good representation of random noise because it only displays the maximum value in each bucket and ignores the true randomness of the noise

Display detector types

- example with a comb signal (equal-amplitude tones) and sample / peak detectors
 - the sample detector indicates different amplitudes depending on the position of the signal within the buckets

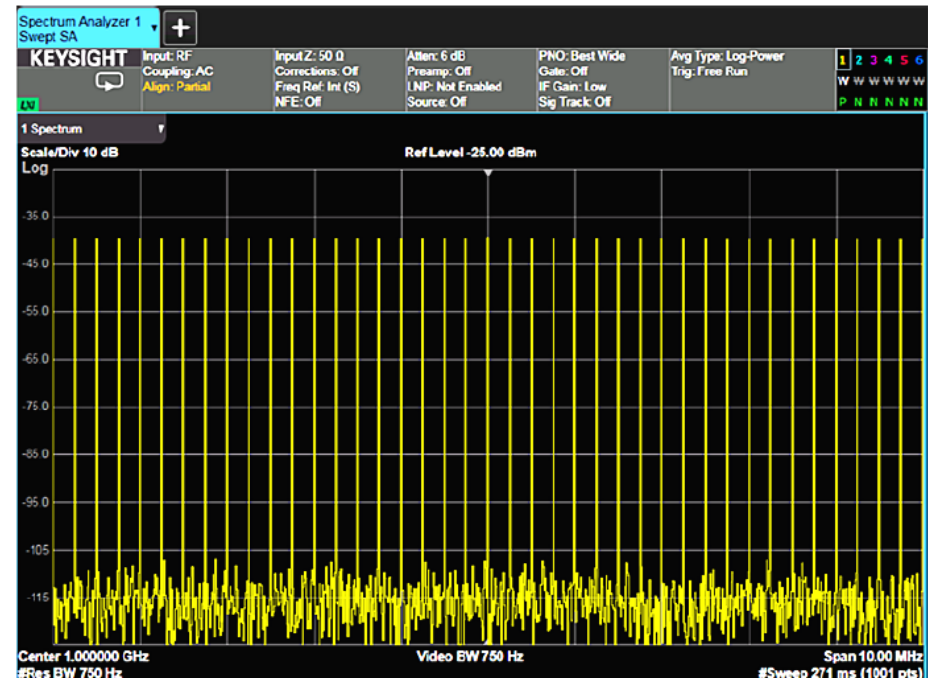
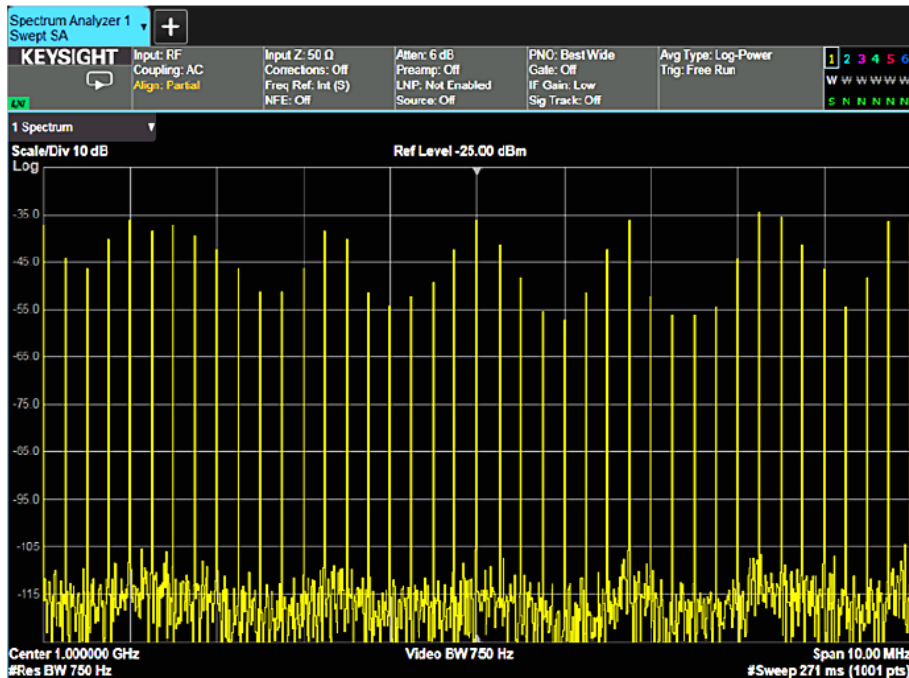

Display detector types

- Negative peak detector
 - selects the minimum amplitude value encountered in each bucket
 - not used as often as other types of detection
 - can be useful for differentiating CW from impulsive signals
 - (for example in EMC testing)
- Normal detection
 - this detection mode should give a better visual display of random noise (compared to the peak detector) ...
 - ... and avoid the missed-signal problem of the sample mode

Display detector types

- if the signal level within the bucket both rises and falls, the signal is classified as noise
 - in that case, odd-numbered data point displays the maximum value within the bucket and an even-numbered data point displays the minimum value
- in case a sinusoidal signal spread over many display points (because of a wider RBW) is encountered, the level only rises in some buckets and then only falls in other buckets
 - in that case, the maximum value within these buckets is displayed
- this algorithm may not work well in case the RBW is narrower than the span of individual buckets
 - generally, only the peak detector will do a 100 % good job for the sinusoidal signals

Display detector types

- Average detection
 - although modern digital modulation schemes have noise-like characteristics, sample detection is not sufficient for these signals
 - integration of the rms values is required for these measurements
 - average detection sums power across the frequency buckets
 - uses all the data values collected within bucket interval
 - Keysight's SAs let the user to choose the averaging type:
 - power (rms) averaging - square root of the average of the squares of the voltage data measured during the bucket interval
 - voltage averaging - averages the linear voltage data of the envelope signal measured during the bucket interval
 - log-power (video) averaging - averages the logarithmic amplitude values (dB) of the envelope signal during the bucket interval

Display detector types

- EMI detectors – average and quasi-peak
 - voltage averaging, as described in the previous section, can be used for measuring narrowband signals that might be masked by the presence of broadband impulsive noise
 - quasi-peak (QPK, QPD) detector is used exclusively in EMI testing
 - a weighted form of peak detection - the indication of the QPD depends on the peak amplitude of the signal and on its pulse repetition rate
 - for CW signals, the indication of all the detectors (peak, QPK, ...) should be the same
 - the QPD was developed to measure and quantify the “annoyance factor” of impulse signals disrupting the legacy radio broadcasting

Averaging methods

- there are multiple processes in a spectrum analyzer that can be used to smooth the variations in the indicated amplitude

1) average detection

- described previously; takes all the points measured within the buckets and averages them

2) video filtering

- to reduce the effect of noise on the displayed signal amplitude, the SAs can smooth the displayed trace
- SAs include a variable video filter for this purpose
- the video filter is a low-pass filter that comes after the envelope detector and determines the bandwidth of the video signal

Averaging methods

- when the video bandwidth is reduced so the $VBW < RBW$, the video system can no longer follow the more rapid variations of the envelope of the signal(s) passing through the IF chain
 - this results in averaging or smoothing of the displayed signal
 - this effect is most noticeable in measuring noise, particularly when the a wider resolution bandwidth (RBW) is used
 - because the video filter has its own response time, the sweep time increases while reducing the VBW below the current RBW

3) trace averaging

- this method is available thanks to the modern digital signal processing and display
- averaging is done over two or more sweeps on a point-by-point basis – each point is averaged with the previously averaged data

Modern SAs

- the all-analog signal processing described previously is not used anymore in the modern spectrum analyzers
 - with the availability of high-performance analog-to-digital converters (and other digital circuitry), the latest spectrum analyzers digitize incoming signals much earlier in the signal path
 - current SAs typically keep the analog input and signal mixing and then use a all-digital IF section (signal on the last IF is digitized and all the subsequent processing is done digitally)
 - this includes digital IF filters which can have much better characteristics compared to analog filters (amplitude accuracy, speed, selectivity)

Modern SAs

- example of the all-digital IF in Keysight's X-Series SAs

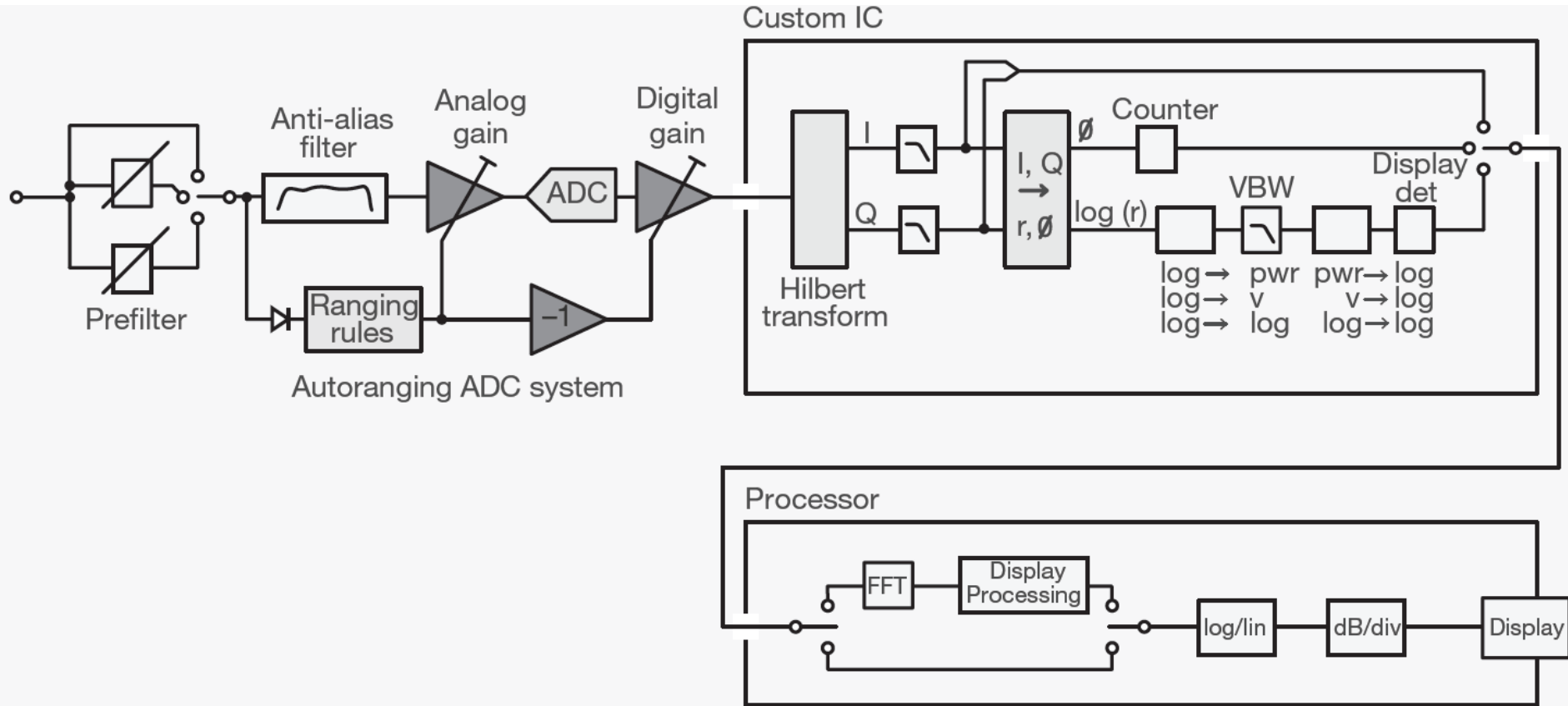

Modern SAs

- digital IF has a great impact on spectrum analyzer performance:
 - better accuracy (the digital signal processing is error free compared to analog signal path)
 - much more accurate digitally implemented logarithmic amplification
 - power/voltage/log averaging modes
 - high resolution frequency counting (observes not only the zero crossings on the IF signal, but also the phase)
 - IF filtering – better selectivity, digital filters are faster and can compensate for freq/amp changes with fast sweeping, more RBW settings, even very narrow filters
 - FFT processing of wider blocks – faster measurement

Recommended meas. procedure

- preset – load default settings; start with a defined state
 - the SA will sweep across it's whole frequency range
- find the signal of interest:
 - set the center frequency and span to the expected location of the signal of interest (Markers can be useful to locate the signal)
 - find the signal („max hold“ function can be useful) and adjust the CF and span accordingly
- depending on the signal level, change the vertical settings:
 - Ref Level – level on the top of the screen
 - Attenuation, Preamplifier (if needed to get the best sensitivity)
 - Scaling – dB/division; if needed

Recommended meas. procedure

- RBW (resolution bandwidth)
 - depending on the nature and level of the signal, the RBW can be adjusted to get lower noise floor
- change other settings / features
 - traces (multiple traces, different display modes)
 - triggering (RF burst, Video trigger)
 - display detectors
 - averaging
 - markers, peak search
 -

Zero Span mode

- „Zero Span“ is a special display/measurement mode which completely changes the usual behaviour of the SA
 - in this mode, the SA is measuring on a single frequency (it is not sweeping) and the x-axis shows time instead of frequency
 - very useful when it's needed to display how the RF envelope level of the signal changes in time (for pulsed signals)
 - rise time for pulses is inversely proportional to the RBW setting
 - Zero Span mode can be used in combination with the “RF Burst” or “Video” trigger to start the capture when there is a pulsed RF signal present at the input

Important specifications

- frequency range
- frequency accuracy - timebase accuracy, aging, ...
- IF analysis bandwidth (signal analyzers)
- dynamic range - noise level (DANL), TOI, SHI, gain compression
- amplitude accuracy - abs. accuracy at 50 MHz, flatness, linearity, attenuator switching accuracy; (maximum safe input)
- phase noise
- RBW - bandwidths, accuracy, selectivity
- measurement speed
- spurious responses
-

Signal analyzers

- signal analyzers are based on the traditional spectrum analyzers and they bring many new features and capabilities
 - all the functions of the usual swept spectrum analyzer
 - + vector signal analysis / digital modulation analysis
 - WiFi, Bluetooth, LTE, 5G, custom vector modulations, OFDM, ...
 - + advanced measurements on the displayed signal
 - channel power, adjacent channel power (ACP), occupied bandwidth, CCDF, ..
 - + specialized measurement applications
 - **analog demodulation** – SA can be used like the usual modulation analyzer
 - **phase noise** measurements on various oscillators or RF signal sources
 - **noise figure** measurement of amplifiers, active mixers, ...
 - **EMI** – SA can be used in a role of a pre-compliance EMI receiver

Vector signal analysis

- 5G NR application example:

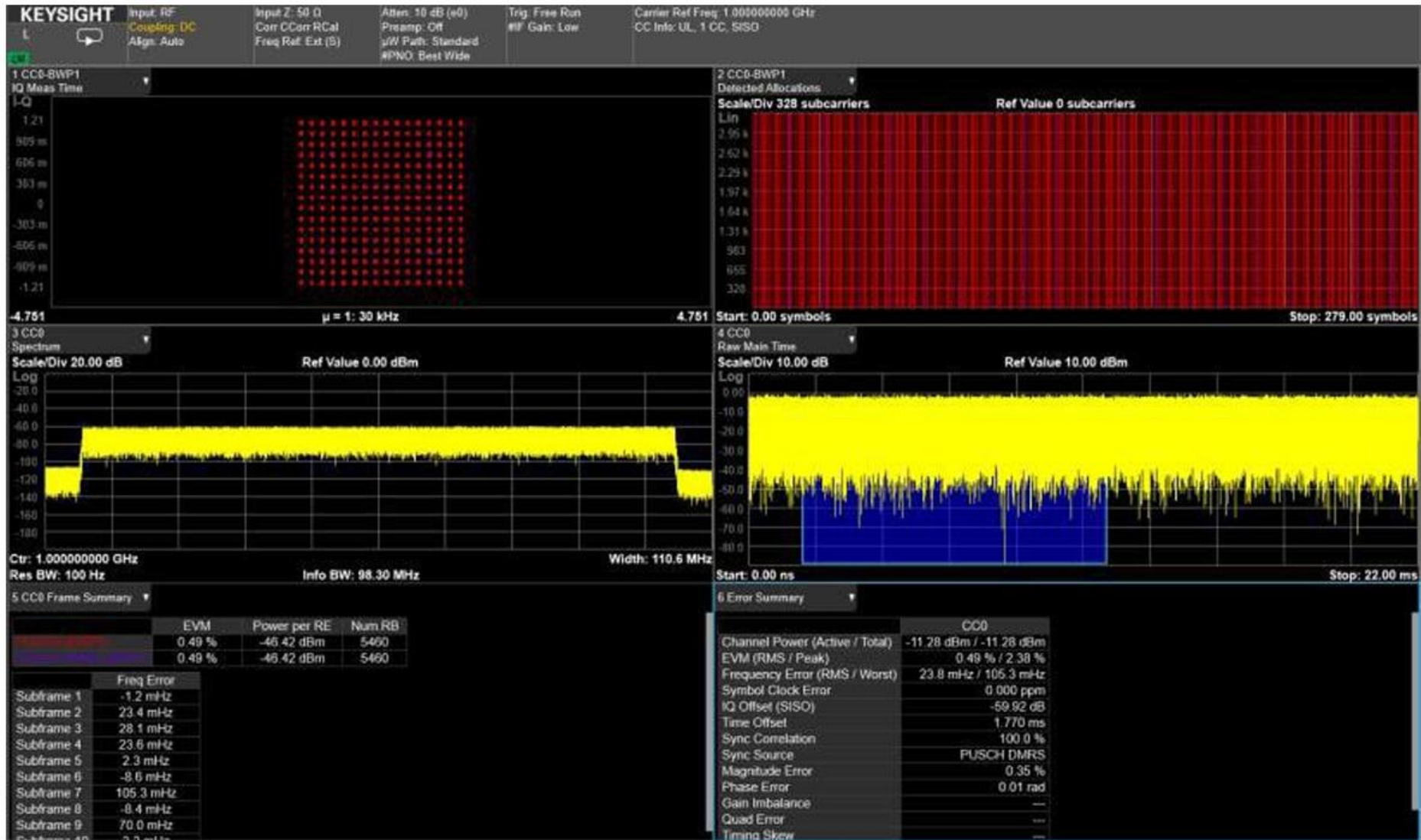

Phase noise application

- phase noise measurement example:



Noise figure application

- noise figure measurement example:

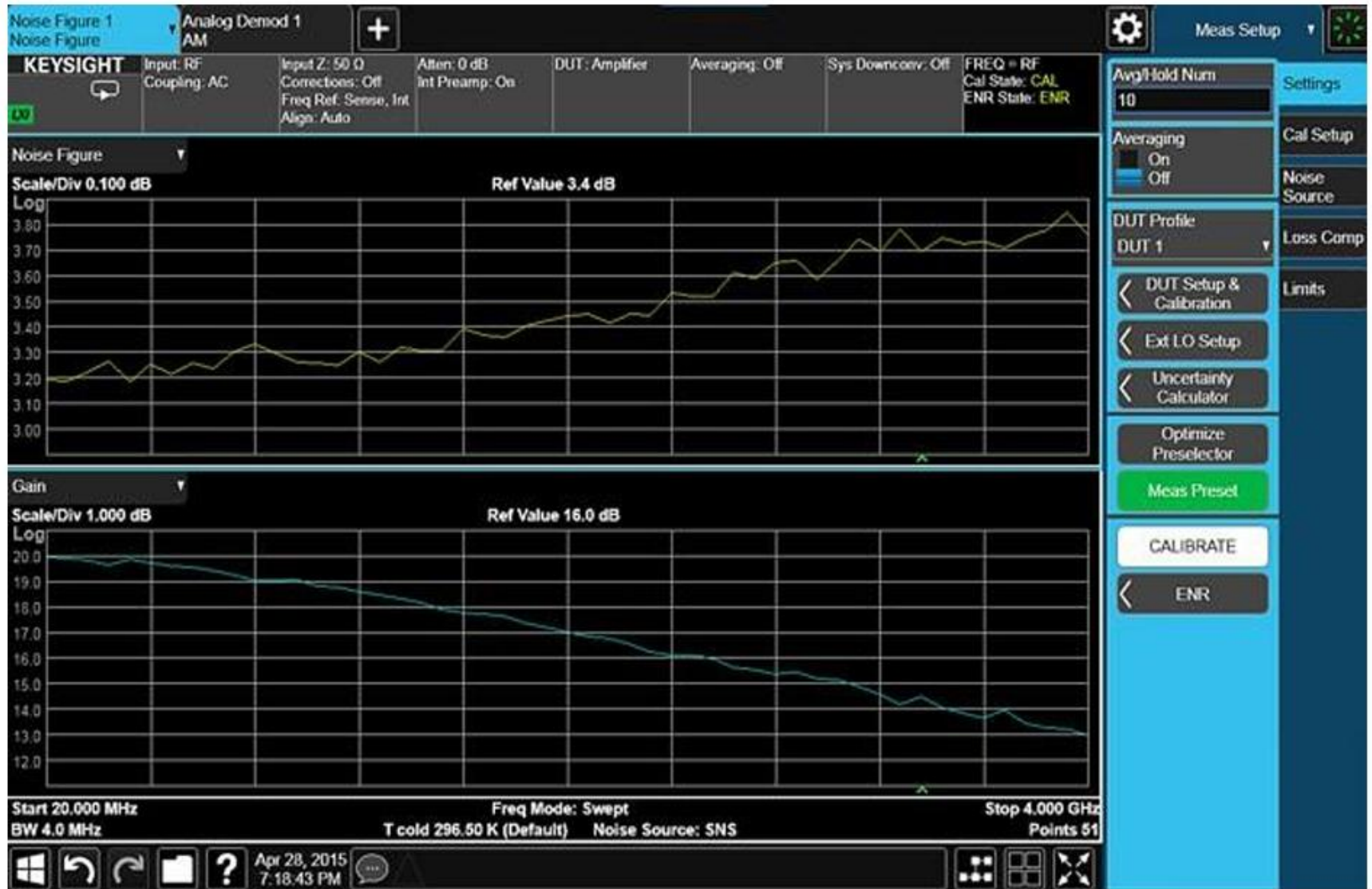

EMI application

- EMI measurement example:

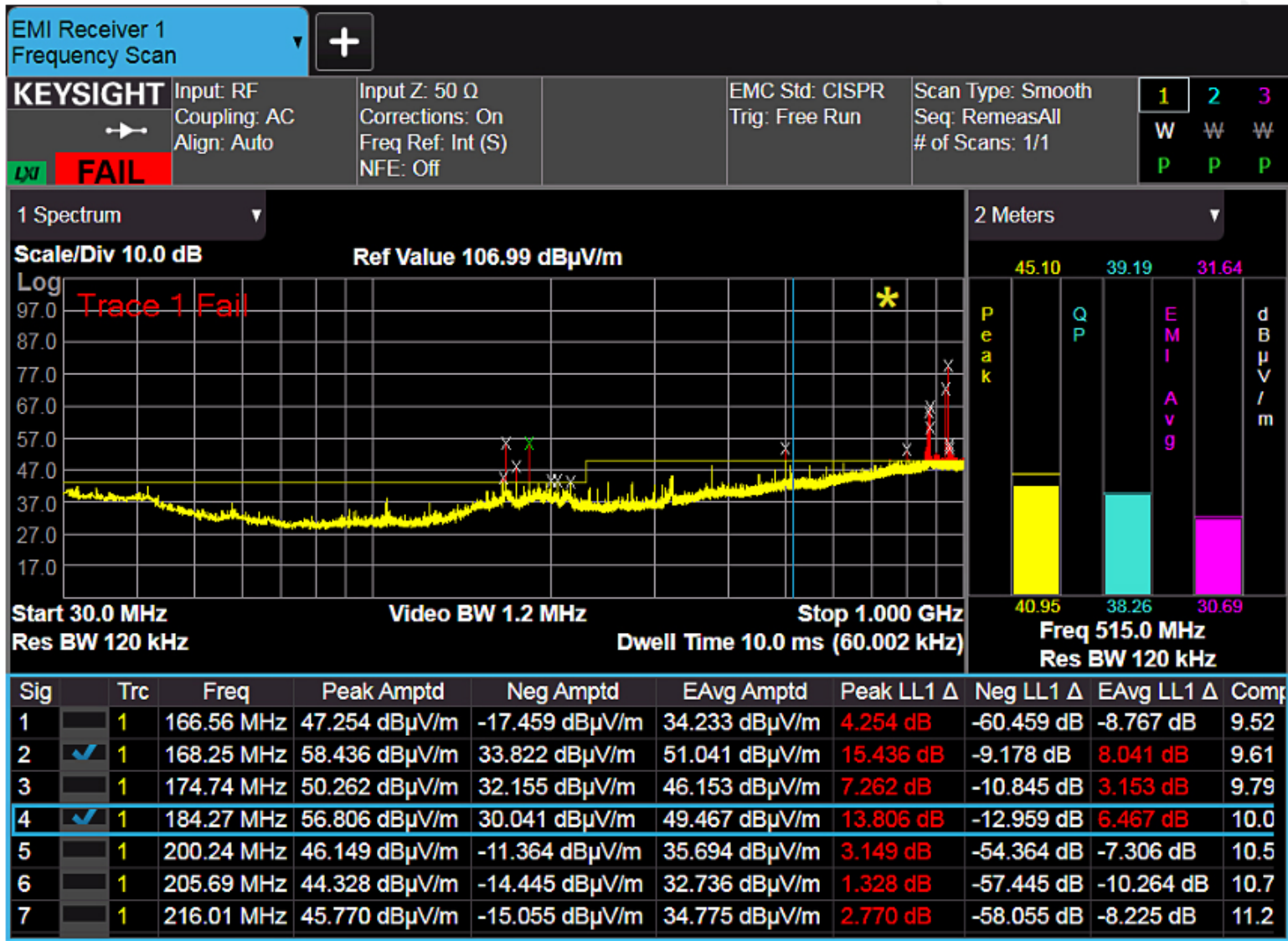

Signal analyzers

- signal analyzers use advanced digital IF processing (with high bandwidth high speed ADC) to capture gapless time/frequency blocks of the input signal
 - the frequency span for this processing is called “IF bandwidth” and it is one of the key parameters for signal analyzers
 - latest Keysight’s signal analyzers can have up to 4 GHz IF BW
 - the maximum length of the captured signal block depends on the internal sample memory; maximum for Keysight’s SAs is 16 GB
 - the captured block of I/Q data can be processed in any required way in the analysis software (digital demodulation, pulse, ...) ...
 - ... or it can be saved or exported for later use in some external application (Matlab, ...)

PathWave 89600 VSA

- Keysight offers the 89600 VSA PC application which can be used for in-depth signal analysis
 - modules for common cellular, wlan and other comm standards
 - 5G, 4G, 3G; 802.11xx; NB-IoT DVB-S, ...
 - general purpose custom digital demodulation; custom OFDM
 - radar signals – pulsed or FMCW
- 89600 VSA can be connected to basically any signal capture device from Keysight – SAs, oscilloscopes, digitizers
 - can run directly on the instrument (Windows based) or on an external PC connected via LAN or USB
- very useful is the record/playback function which can use the whole capture memory of the signal capture device

Real Time Spectrum Analyzer (RTSA)

- most of the signal analyzers available today offer the RTSA measurement mode
- RTSA uses similar hardware as the signal/spectrum analyzers
 - fully digital wideband IF section – up to 2 GHz of RTSA BW
 - the difference is in the speed of signal processing and the optimisation for fast FFT spectrum calculation
 - sampling is continuous and the RTSA uses all of the captured samples for spectrum calculation → no „dead time“

swept SA

- by tuning the local oscillator in a certain range, a "scanning" of the RF spectrum occurs
 - the scanning is typically relatively slow and the probability of picking up an intermittent pulsed signal is quite low

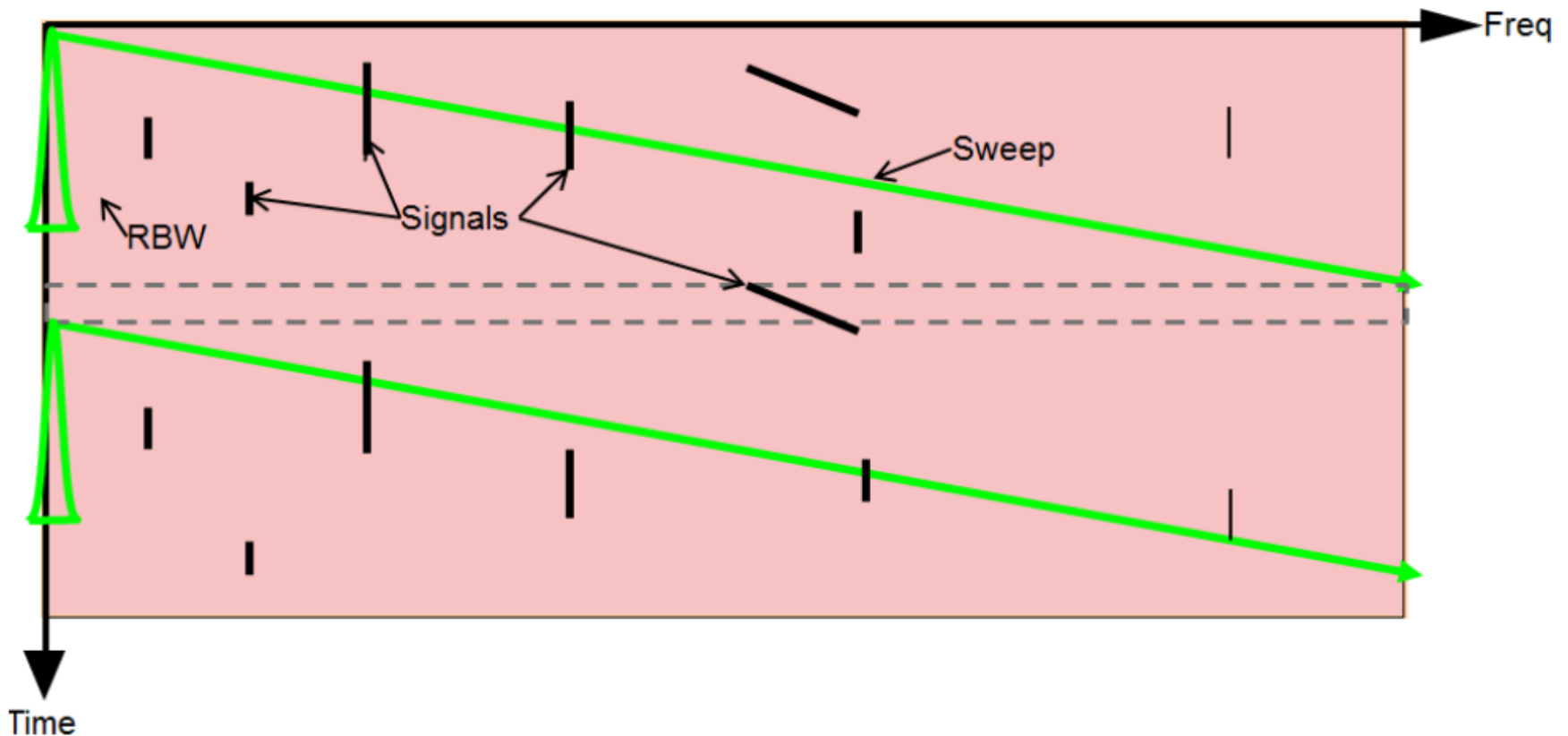

"Real time" spectrum analyzer

- RTSA:

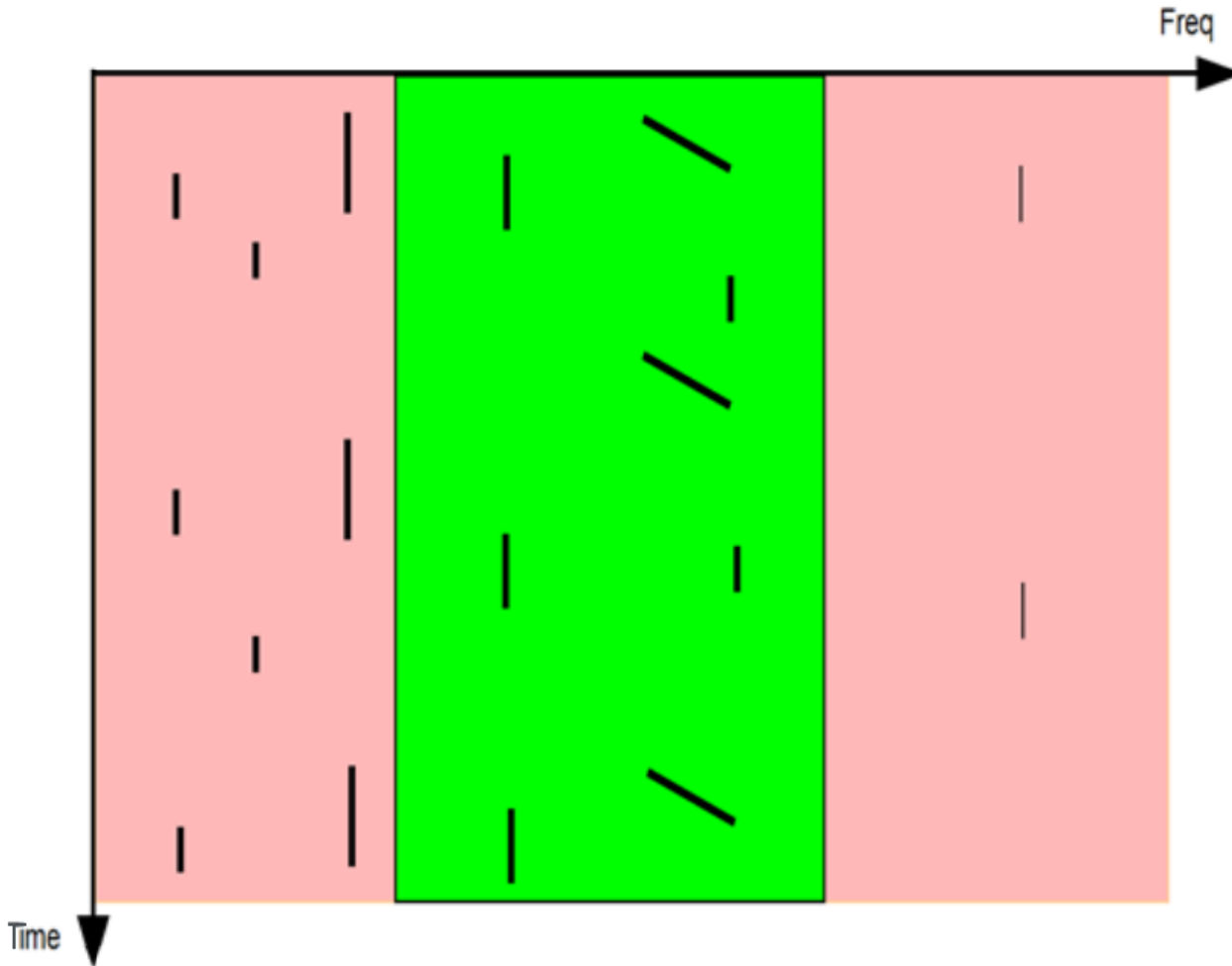

"Real time" spectrum analyzer

- the duration of "real time" signal processing is not limited with current analyzers (does not apply in the case of data recording)
- "real time" analysis is possible only in certain frequency span
 - depends on the RF/IF signal path and the speed of the digital processing (sampling speed, ...)
- sample processing must take less time than the capture:

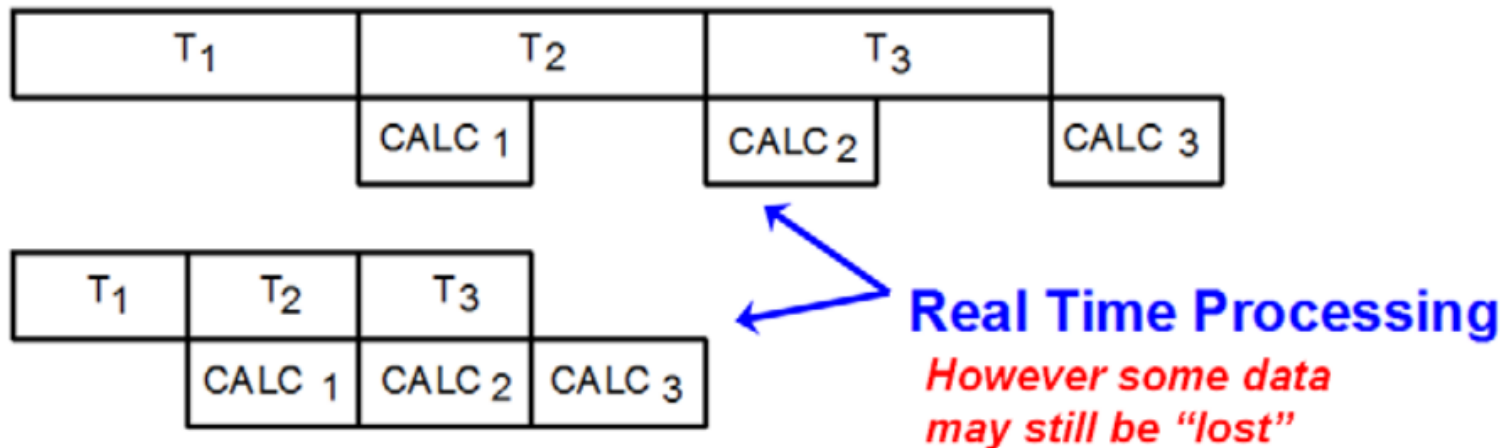

"Real time" spectrum analyzer

- if the calculations with samples would take longer, the results wouldn't be continuous (this is how common FFT analyzers work):

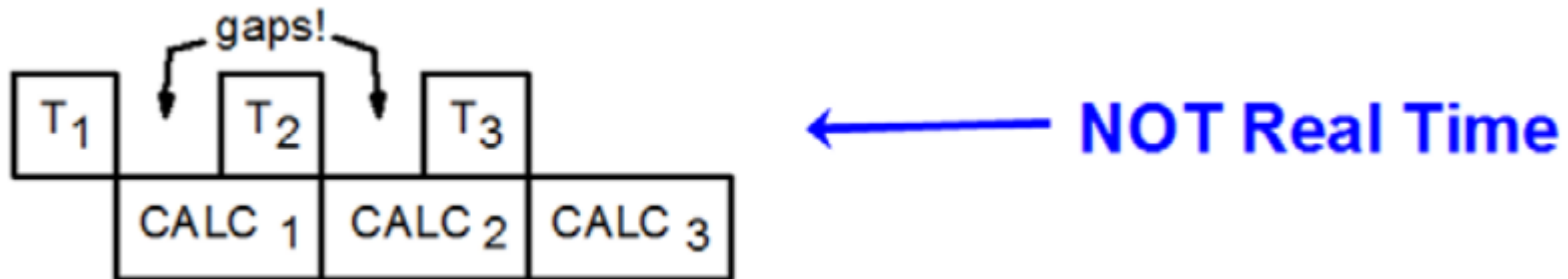

- before performing the FFT, a windowing function is always applied to the relevant group of captured samples in the time domain
 - limits the amplitude of unwanted false spectral components ...
 - ... but, at the same time, limits the amplitude of true signals captured near the edges of the sample buckets

"Real time" spectrum analyzer

- this effect of the windowing function is limited by using the calculation with overlapping groups of samples:

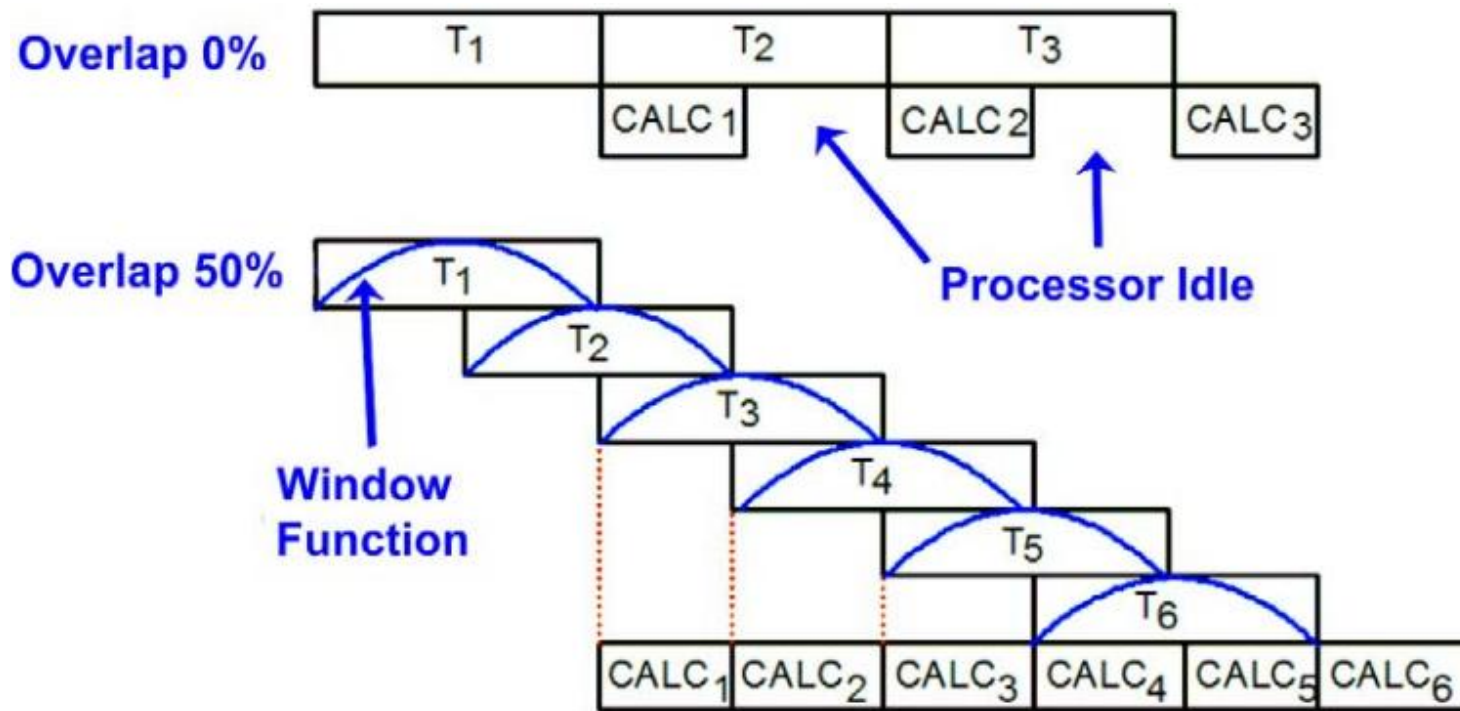

RTSA - POI

- POI (Probability of Intercept) (with full amplitude accuracy)
 - important parameter defined as the shortest duration of a certain signal necessary to ensure full accuracy of the indicated level
 - to achieve full amplitude accuracy, the signal must fill at least one entire group of samples from which the FFT is calculated
 - for a detection of a signal presence (with an error in the displayed level), a much shorter signal duration is typically sufficient
 - in this case, the time for a 100% probability of a signal capture also depends on the difference between the signal level and the noise threshold level of the analyzer

RTSA - POI

- an example for the N9042B:

	N9042RTAB	N9042RTBB	N9042RTEB	N9042RTFB
Center frequency	Maximum real-time analysis bandwidth			
≥ 2 Hz to 670 MHz	(center frequency + 80 MHz) x 2, up to 1 GHz		(center frequency + 80 MHz) x 2	
> 670 MHz to 3.5 GHz	1 GHz		1.5 GHz	
> 3.5 GHz to 50 GHz	1 GHz		2 GHz	
Minimum signal duration for 100% probability of intercept (POI) with full amplitude accuracy (with at least 50% overlap)	15.4 μs	227 ns	15.4 μs	227 ns
Histogram	Max 1 GHz BW (span)		Max 2 GHz BW (span)	
Maximum sample rate (Hz)	1.247259439e9	1.247259439e9	2.4e9	2.4e9
(Gap free) FFT processing rate	4,687,500 FFT/sec			

RTSA - display

- RTSAs measure very quickly (~ millions of spectrum calculations in a given bandwidth per second)
- the screen redraw speed can be, for example, 30 frames/s
 - each new display of the spectrum must meaningfully combine hundreds of thousands of measurements
- most commonly used display forms:
 - histogram (density) – frequency on x-axis, level on y-axis; the probability of the signal at a given frequency is indicated by a color scale; easy identification of overlapping signals
 - spectrogram – frequency on x-axis, time on the y-axis (signal history); level at a given time on a given frequency indicated by color
 - PvT (Power vs. Time) – displays a signal power envelope vs. time in the given frequency span (not selective)

Histogram display (density)

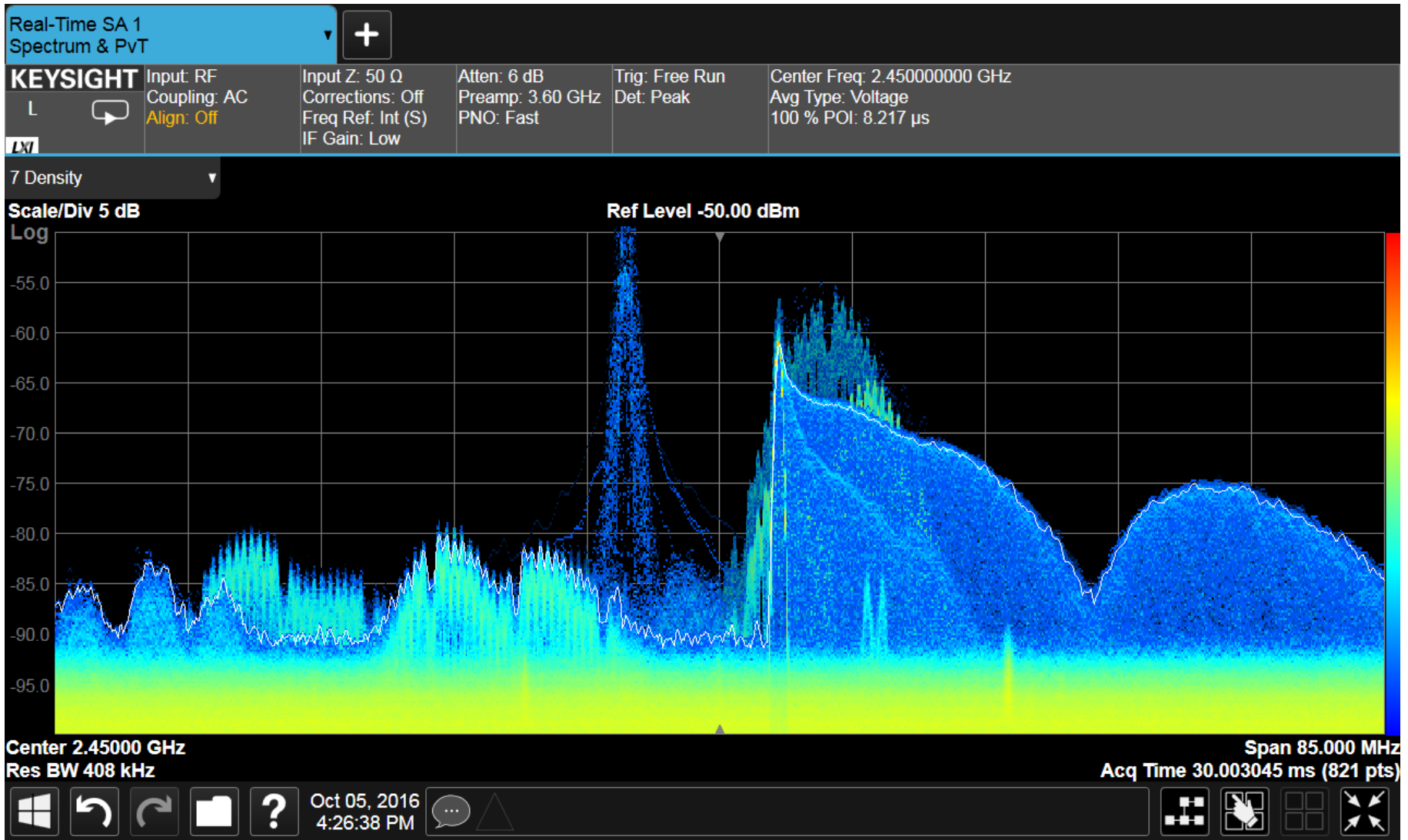

Spectrum + Spectrogram display

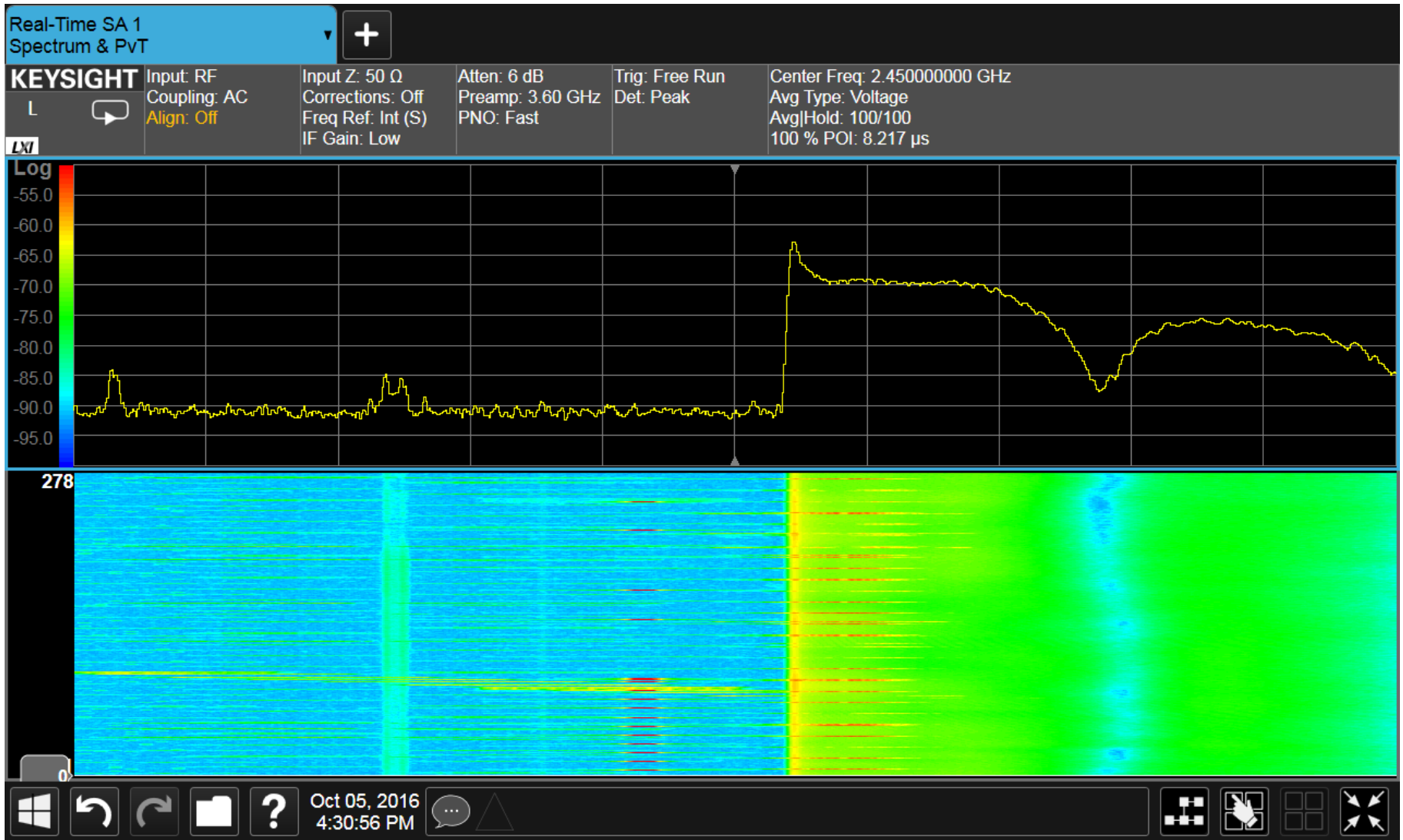

PvT + Spectrum

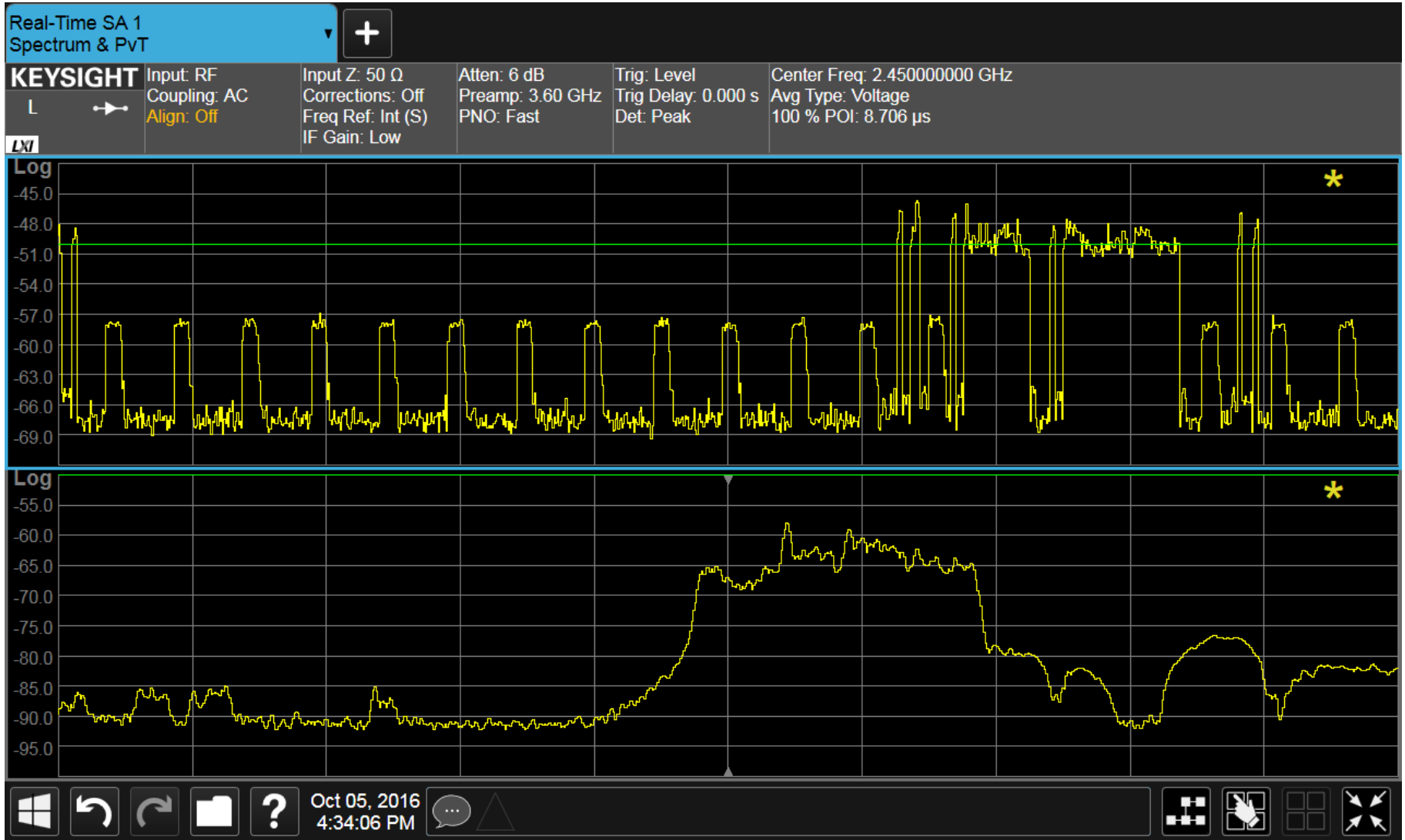

RTSA - „hidden“ signals

- the advanced histogram display allows for an easy detection of various interfering signals:

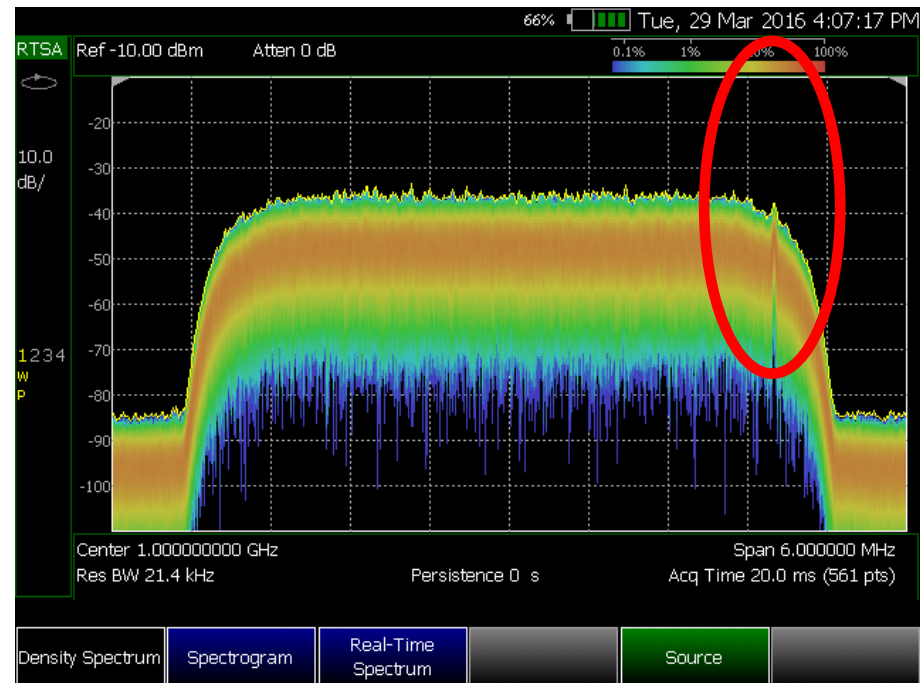

RTSA vs. swept SA

- swept SA:
 - best for signals which are stable in time (CW)
 - + beter dynamic range
 - + generally better amplitude accuracy
 - + fast sweeps across wide frequency spans
 - not suitable for dynamic pulsed signals which are changing amplitude and frequency quickly
 - it does not allow a quick overall overview of the situation in a certain frequency band

RTSA vs. swept SA

- RTSA:
 - optimal for monitoring the spectrum of modern dynamic signals (wireless communications, radars, ...)
 - + continuous spectrum monitoring in certain frequency span (currently up to 2 GHz)
 - + no time gaps; captures and displays everything within the span
 - typically worse amplitude accuracy compared to the swept SAs
 - worse dynamic range
 - slower when scanning across wider frequency spans (wider than the maximum bandwidth of the RTSA system)

Oscilloscopes as SAs

- modern oscilloscopes can be used as broadband digitizers with high sample rate and large memory
 - from DC up to the bandwidth of the oscilloscope
 - memory lengths of up to 2 Gpts
 - hw accelerated FFT analysis for very fast spectrum display
 - captured data can be downloaded and used by external software to perform signal analysis (Keysight's 89600 VSA, Matlab, ...)
- limited ADC resolution; broadband → higher noise floor; typically worse signal integrity than the signal analyzers
- baseband signal capture → high sample rate → very short record lengths (~ ms)

Oscilloscopes as SAs

- Keysight's MXR and UXR oscilloscopes address some of the inherent disadvantages
 - DDC (digital down conversion)
 - oscilloscope can take part of the spectrum and translate it digitally to lower center frequency (with lower sample rate)
 - because of the lower sample rate, the available capture time is much longer seconds instead of ms
 - maximum DDC analysis bandwidth is 2,16 GHz

DDC option/configuration	Bandwidth range	Capture time @ max sample rate		
		Std Mem 500 Mpts real 125 MSa complex	UXR0000-01G option 1 Gpt real 250 MSa complex	UXR0000-02G option 2 Gpts real 400 MSa complex
No DDC (256 GSa/s)	Up to 110 GHz	1.95 ms	3.9 ms	7.8 ms
No DDC (128 GSa/s)	Up to 33 GHz	3.9 ms	7.8 ms	15.6 ms
STD DDC 50 to 200 MSa/s complex	40 MHz to 160 MHz	625 ms	1.25 s	2 s
UXR0000-602/N2163A-602 50 to 3200 MSa/s complex	40 MHz to 2.16 GHz	39 ms	78 ms	125 ms

Oscilloscopes as SAs

- RTSA (Real Time Spectrum Analyzer)
 - MXR and UXR scopes can perform gapless signal capture and processing and work as the RTSA mode in Signal Analyzers
 - maximum RTSA bandwidth is 320 MHz (shared between channels 1 - 4 and 5 - 8)
- „frequency extension“
 - with this option, the signal analysis (RTSA / DDC) can be performed in the whole frequency band of the scope hw (not limited by the bandwidth available for normal time domain scope measurements)
 - up to 6 GHz for MXR
 - up to 33, 70 or 113 GHz for the UXR (depending on the hw)

Oscilloscopes as SAs

Model	Bandwidth (maximum)		Connector	Power required		Sample rate (maximum)
	4-Channel	2-channel		4-channel	2-channel	
UXR1104B	UXR1102B	110 GHz	1 mm	200 to 240 V _{ac} 2615 VA(Max)	110 to 240 V _{ac} 1350 VA (Max)	256 GSa/s
UXR1004B	UXR1002B	100 GHz				
UXR0804B	UXR0802B	80 GHz				
UXR0704BP	UXR0702BP	70 GHz				
UXR0594BP	UXR0592BP	59 GHz				
UXR0404BP	UXR0402BP	40 GHz				
UXR0254BP	UXR0252BP	25 GHz				
N/A	UXR0051BP¹	5 GHz	1.85 mm			
UXR0704B	UXR0702B	70 GHz				
UXR0594B	UXR0592B	59 GHz				
UXR0504B	UXR0502B	50 GHz				
UXR0404B	UXR0402B	40 GHz	3.5 mm	100 to 240 V _{ac} 1350 VA (Max)	N/A	128 GSa/s
UXR0334B	N/A	33 GHz				
UXR0254B		25 GHz				
UXR0204B		20 GHz				
UXR0164B		16 GHz				
UXR0134B		13 GHz				
UXR0104B		10 GHz				

Keysight Signal Analysis Portfolio

Real-time: 510 MHz

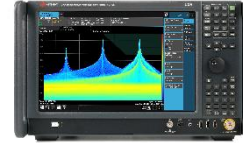

N9040B UXA
2 Hz to 50 GHz
1 GHz max. BW

Real-time: 510 MHz



N9041B UXA
2 Hz to 110 GHz
1 GHz max. BW internal
5 GHz max. BW external

Real-time: 2 GHz



N9042B UXA
2 Hz to 50 GHz
4 GHz max. BW internal
11 GHz max. BW external

Real-time: 510 MHz



N9030B PXA
2 Hz to 50 GHz
510 MHz max. BW

Real-time: 2 GHz



N9032B PXA
2 Hz to 55 GHz
2 GHz max. BW

Real-time: 160 MHz



N9020B MXA
10 Hz to 50 GHz
160 MHz max. BW

Real-time: 510 MHz



N9021B MXA
10 Hz to 50 GHz
510 MHz max. BW



N9010B EXA
10 Hz to 44 GHz
40 MHz max. BW



N9000B CXA
9 kHz to 26.5 GHz
25 MHz max. BW



M9421A VXT PXI
60 MHz to 6 GHz
160 MHz max. BW



M9410A/11A VXT PXI
1 MHz to 6 GHz
1.2 GHz max. BW



M9415A/16A VXT PXI
380 MHz to 12.3 GHz
1.2 GHz max. BW

MXR / UXR oscilloscopes



- 4 or 8 channels
- up to 6 GHz BW
- 16 GSs/s for all channels
- 400 Mps/channel
- 10 bit ADC; low noise frontend
- DDC and RTSA features



- 1 / 2 / 4 channels
- up to 110 GHz BW
- 256 GSs/s for all channels
- 2 Gps/channel
- 10 bit ADC; low noise frontend
- DDC and RTSA features