

Signal Generation Basics

Introduction

- signal generator (signal source) is an instrument which outputs a defined signal (used for various purposes)
 - signal can be an unmodulated (harmonic) sine wave...
 - ... or a modulated signal (analog, digital, pulse, ...)
 - signal can be produced at a given frequency and amplitude
- signal generators can be used for the testing of receivers, various sub-components and systems
 - the goal is to produce precise and stable (repeatable) test signals
 - signal generators can also apply impairments to test the robustness of the DUTs (receivers, ...)

Testing components

- examples of component tests:
- measuring the influence of the DUT on the input signal
- any passive or active DUT
- modulated/unmodulated signals
- 2-tone tests; intermodulation distortion



Testing components

- examples of component tests:
- supplying a RF signal to a receiver under test
- generating I/Q baseband signals for a tested transmitter

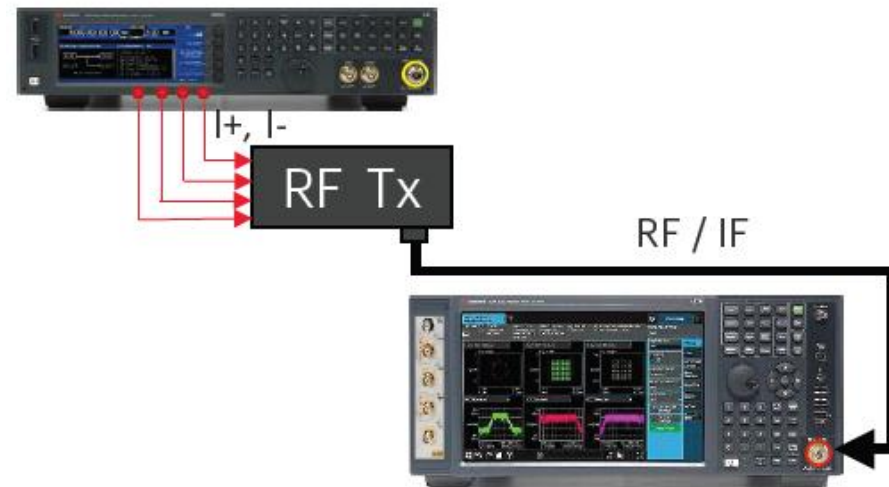
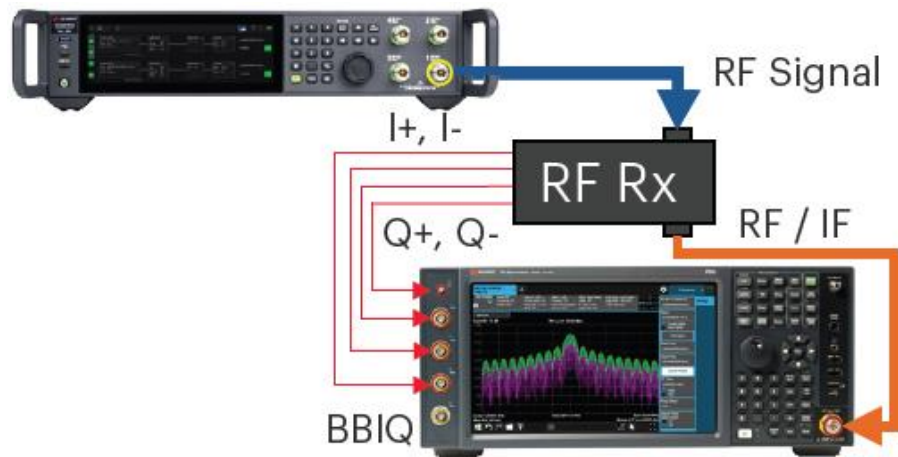

Testing components

- examples of component tests:
- signal generator as a component (RF modulator):

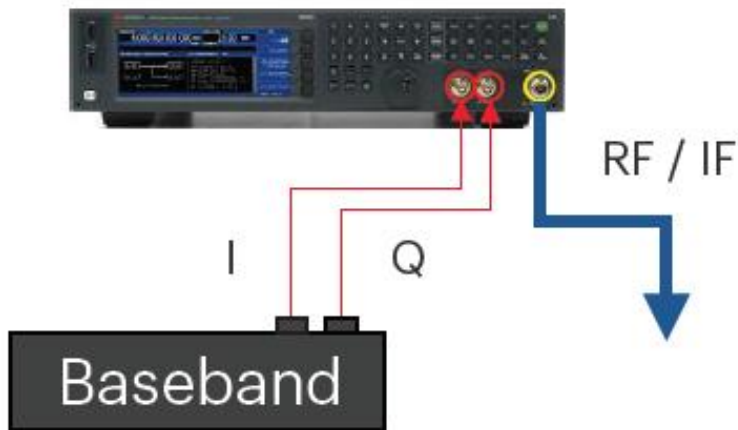

- signal generator as a component (local oscillator):

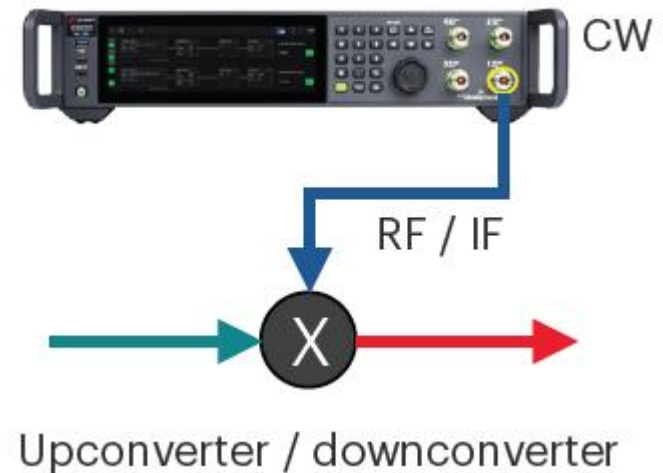

Testing receivers

- sensitivity, dynamic range, accuracy
 - generator produces a test signal at defined level and the receiver has to be able to receive it correctly
 - the receiver should be able to report the level of the received signal
- co-channel rejection
 - two signal generators – the desired signal + in-band interferer
 - testing the immunity of the receiver to other signals present in the same channel

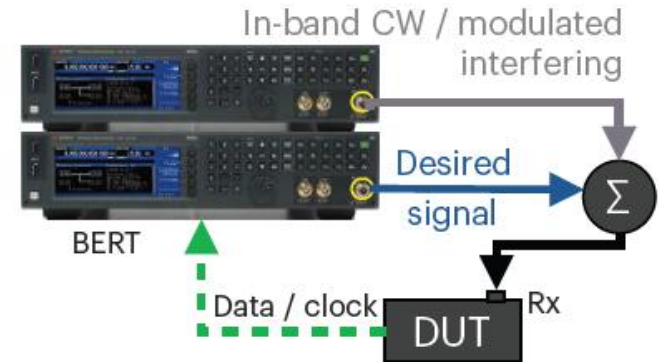

Testing receivers

- immunity to out-of-band signals
 - testing of the sensitivity to out-of band / adjacent band interfering signals
 - signals of the same comm standard present in adjacent channels
 - spurious signals
- fading immunity
 - test signal is put through a channel emulator which can simulate a complex multipath propagation and attenuation of the signal

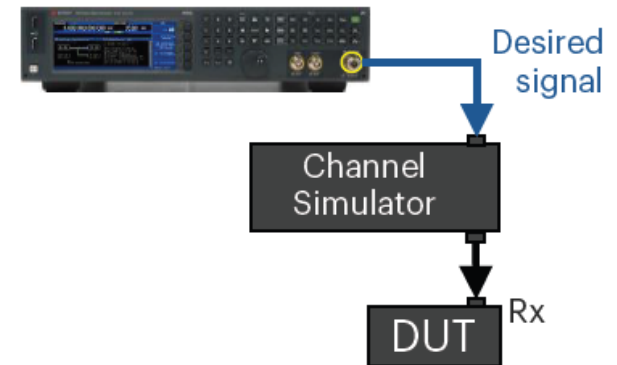
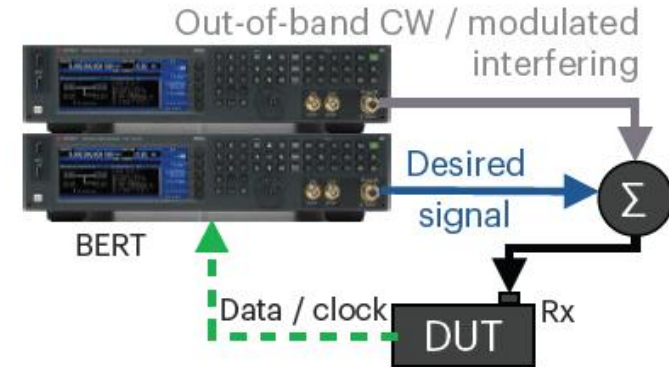

Types of signal generators

- waveform / function generators
 - lower frequency generators capable of generating various basic shapes of waveforms – sine, square, ramp, pulse, triangle, DC, ...
 - generation of arbitrary (user defined) waveforms
 - output waveforms can be modulated (AM, FM, burst, ...)
 - output is typically very clean with low distortion
 - typical frequency range is from very low frequencies (μHz) up to tens or hundreds of MHz (up to 120 MHz for Keysight generators)
 - Keysight offers the „Trueform“ 33500 and 33600 series AWGs
 - can be used to generate high fidelity low frequency signals, for example for baseband I/Q modulating waveforms

Types of signal generators

- high speed AWGs
 - specialized high speed / high bandwidth / high resolution arbitrary waveform generators
 - up to 256 GSa/s sample rate and 80 GHz of analog bandwidth
 - used typically for generating of:
 - high speed digital signals
 - high bandwidth RF signals (FMCW radars, electronic warfare...)
 - can be used to generate basically any signal which fits into the arb memory and the bandwidth of the instrument
 - like the counterpart of oscilloscopes...

Types of signal generators

- RF signal generators
 - the traditional synthesized RF signal generator use a frequency reference, a PLL, series of frequency multiplexers and dividers and a level control chain (amplifiers/attenuators) to get the desired output signal (frequency and amplitude)
- 1) analog signal generators
 - can supply sinusoidal continuous wave (CW) signals and several types of analog modulation like amplitude, frequency, and pulse modulation
 - sweep capabilities (frequency / amplitude)
- 2) vector signal generators
 - all the capabilities of analog SGs + the ability to create digital modulations
 - certain modulation bandwidth around the center/carried frequency
 - basically, the direct counterpart of signal analyzers...

IQ Modulation

- modulation is the process of varying one or more properties of the carrier signal with the modulation signal that contains information to be transmitted
 - **amplitude**, **phase** and **frequency** of the carrier can be changed
- IQ modulation uses two amplitude modulated carriers – the in-phase (I) and the quadrature (Q) component
 - both components are phase shifted by 90° and are orthogonal
 - by adding these two components, it is possible to create an arbitrarily modulated sine wave
 - the vector signal generators use IQ modulators (block diagram)

IQ Modulation

- I/Q phasor diagram:

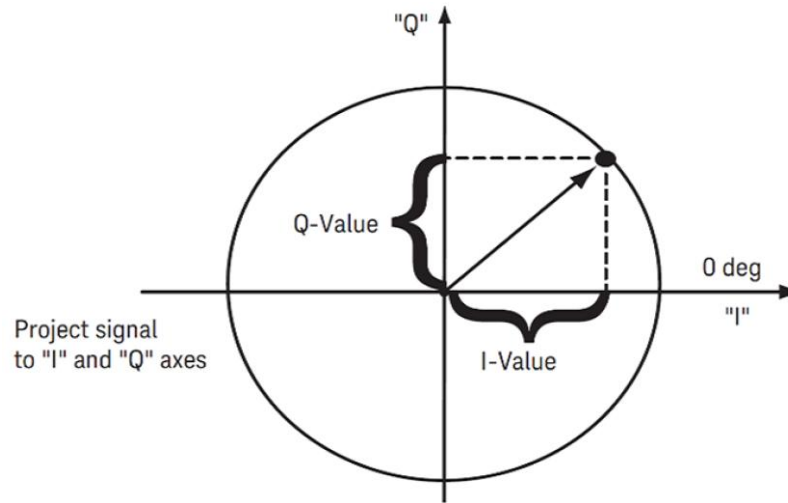

- IQ modulator:

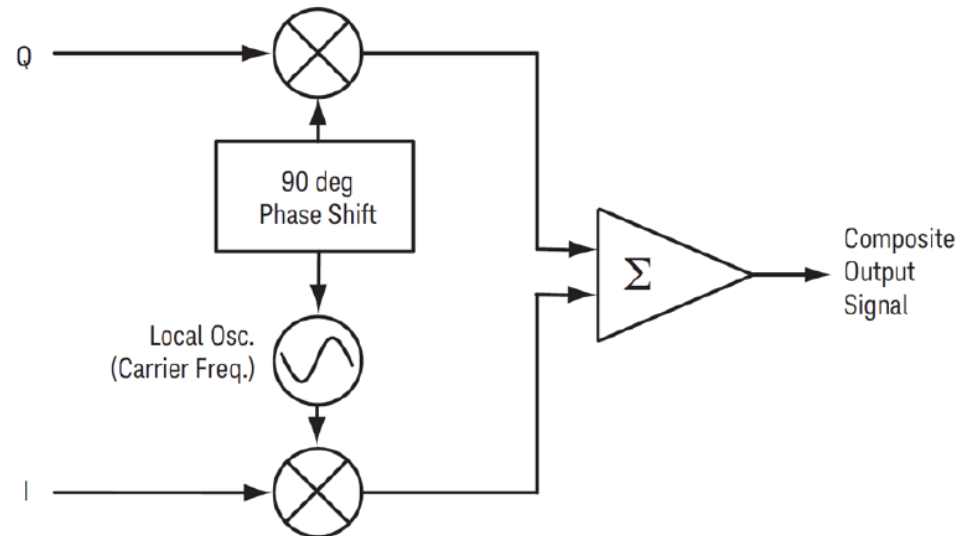

Modulation schemes

- the most common modulation schemes/types are the
 - PSK – phase shift keying
 - FSK – frequency shift keying
 - ASK – amplitude shift keying
 - QAM – quadrature amplitude modulation

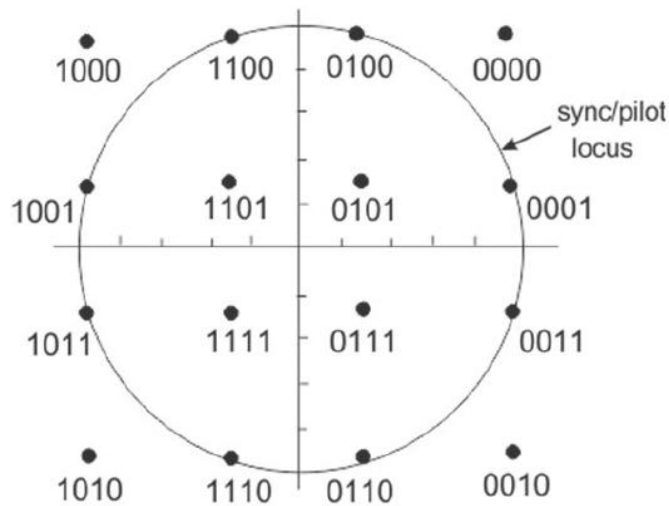

16-QAM Symbol Constellation

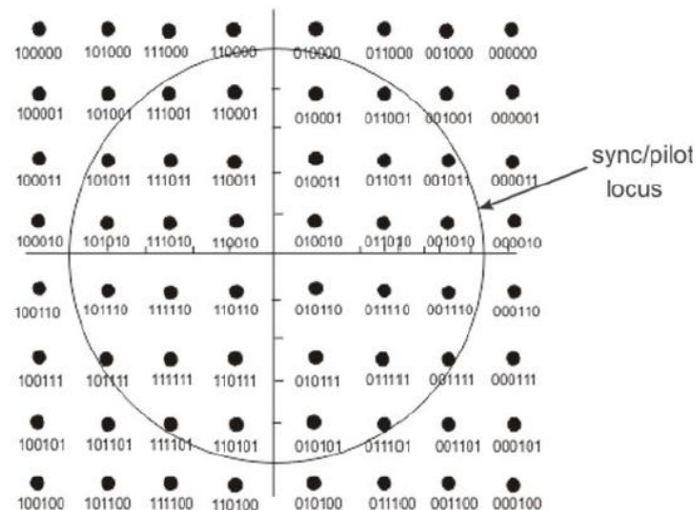

64-QAM Symbol Constellation

Modulation schemes

- a constellation diagram shows the available symbols of the particular modulation format
 - in the case of a 16-QAM format, each symbol represents one of the combinations of four bits; for 64-QAM, it's 6 bits per symbol
 - higher modulation schemes have higher spectral efficiency (more bits per symbol, lower symbol speed and narrower bandwidth)
 - however, as the symbol locations are closer together, the transmission is more prone to errors due to noise and distortion
 - the modern communication technologies can use multiple different modulation schemes and switch between them dynamically as the conditions change

EVM

- an error vector is the vector difference between the ideal I/Q reference signal (constellation point) and the measured signal
 - EVM (Error Vector Magnitude) is the RMS of the error vectors computed and expressed as a percentage of the EVM normalization reference
 - for constellations with constant magnitude (QPSK, BPSK, 8PSK, ...), the „normalization reference“ can be the constellation maximum
 - for constellations with multiple possible magnitudes (QAM, ...), the RMS of reference symbol points is typically used as the normalization reference

$$\% \text{ EVM} = \frac{\sqrt{\frac{1}{N} \sum_{n=0}^{N-1} I_{\text{err}}[n]^2 + Q_{\text{err}}[n]^2}}{\text{EVM Normalization Reference}} \times 100\%$$

where:

- n = symbol index
- N = number of symbols
- $I_{\text{err}} = I_{\text{Ref}} - I_{\text{Meas}}$
- $Q_{\text{err}} = Q_{\text{Ref}} - Q_{\text{Meas}}$

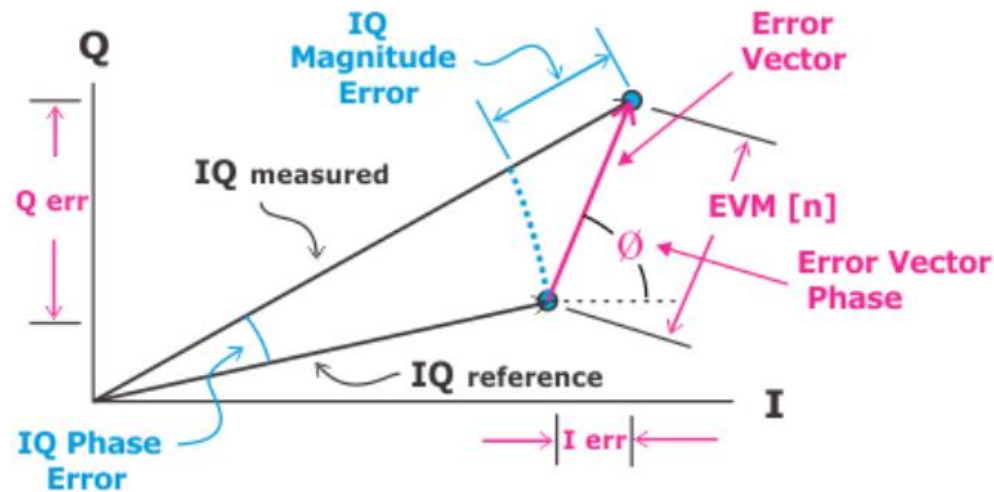

EVM

- vector signal generators can intentionally simulate I/Q impairments to stress-test the DUTs (receivers) or to compensate for imperfections in the signal path
 - **I/Q offset** - DC offsets of the I and Q signals
 - **quadrature angle** – phase offset between the I and Q signals
 - **I/Q skew** - a relative time delay between the I and Q signals
 - **I/Q gain balance** - the amplitude difference between the I and Q
 - **I/Q phase** - the absolute phase of the internal I/Q channel by rotating both I and Q

Types of signal generators

- some of the latest VSGs (**M9484C**) replace the I/Q modulator with direct digital synthesis (DDS) technology
 - up to 8,5 GHz – 14 bit DAC directly to RF (basically a AWG)
 - upconversion for higher output frequencies
 - 2,5 GHz of modulation bandwidth
 - better signal quality than the traditional vector generators – phase noise, modulation quality (EVM), ACP, ...

Traditional baseband architecture

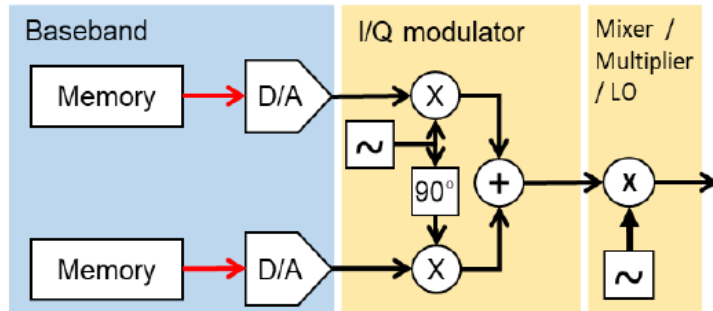

Baseband with DUC architecture

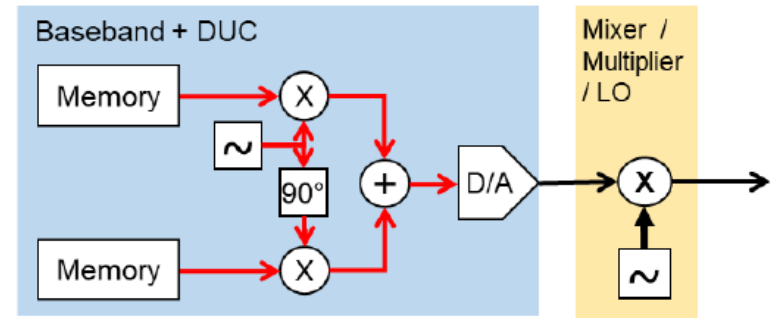

Important parameters

- frequency
 - range typically from 9 kHz up (to 6/7/8 GHz for RF generators and higher for mw instruments)
 - frequency accuracy – defined by the timebase accuracy
 - switching speed – important for certain applications
- amplitude range
 - generators equipped with output attenuators can produce very low levels (< -140 dBm); important for sensitivity testing
 - the maximum output level is a very important parameter for some applications; the rf/mw power is expensive and in some cases, the generator alone can replace an amplifier
 - OTA measurements, receiver tests, compensation of signal path losses

Important parameters

- average and peak envelope power
 - the specified maximum output power applies to CW signal or to the PEP (peak envelope power) for modulated signals
 - modern signals using QAM + OFDM modulation can have large peak to average power ration (PAPR)
 - it is important to know the PAPR and set the output level of the generator so the signal is not clipped in it's power peaks



Important parameters

- spectral purity
 - a perfect signal generator would generate a sine wave at a single frequency without the presence of noise
 - in practice, there is always noise and distortion:
 - phase noise - a frequency domain view of the noise spectrum around the signal; frequency stability of the oscillator
 - harmonics – caused by nonlinearities and the resulting distortion
 - spurs – other parasitic signals present in the output spectrum

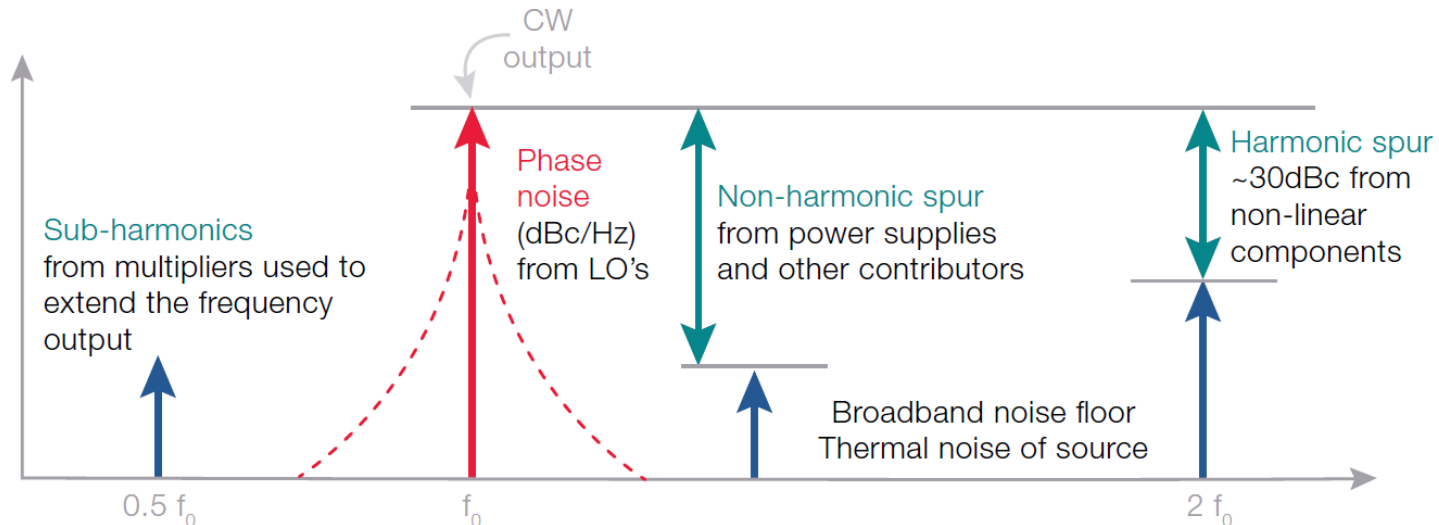

Important parameters

- modulation bandwidth
 - very important for vector signal generators
 - modern communication technologies can use very wide bandwidth
 - for example up to 320 MHz for 802.11be
 - UWB, FMCW radars,
- modulation quality
 - modern standards (mostly WLAN) use very high level modulation formats (4096-QAM) and require very low levels of EVM
 - in order to be able to test the receivers, the vector signal generators need to be very good (EVM ~ -50 dB)

Important parameters

- when testing any DUT using a signal generator, it is very important that the SG has to be better in the measured quantity than the tested device
 - accuracy and stability of level and frequency
 - harmonic distortion, intermodulation distortion
 - phase noise
 - radar applications
 - digital modulations (phase smearing of the symbols; OFDM leakage)
 - residual EVM
 - ...

Software

- signal creation software is a key thing when working with the vector signal generators
 - the signals in the digital form can be generated „manually“ in some general signal processing software (Matlab, ...) ...
 - ... or, it is possible to use applications specialized for this purpose
- Keysight offers various versions of the „PathWave Signal Generation“ (Signal Studio) software
 - some of the variants are targeted to specific wireless standards and some can be used for creation of general modulated signals
 - software is relatively simple to use and offers configuration options specific for the given application
 - desktop (PC) or embedded (latest SGs – VXG, new MXG) versions

Software

Current model ⁴	Communications standard	Current model ⁴	Communications standard	Current model ⁸	Communications standard
N7600C	W-CDMA / HSPA+	N7606C	Bluetooth® (BR, EDR, 4.0 / 4.2, BT5, BT5.1 (AoA and AoD) , BT5.3	N7611C	Broadcast radio (FM Stereo/RDS, DAB, T-DMB)
N7601C	cdma2000® / 1xEV-DO	N7607C	DFS radar profiles	N7623C	Digital video (w / DOCSIS3.1)
N7602C	GSM / EDGE / Evo	N7610C	IoT (Internet of Things) (Wi-SUN, ZigBee®, Z-Wave, LoRa, and HRP UWB)	N7640C	Land-mobile radio
N7612C	TD-SCDMA / HSPA	N7615C	Mobile WiMAX™		
N7624C	LTE / LTE-A FDD	N7617C	WLAN 802.11 a / b / g / j / p / n / ac / ah / af / ax / be		
N7625C	LTE / LTE-A TDD	N7637C	mmWave WLAN 802.11ad / ay		
N7626C	LTE V2X				
N7630C	5GTF (pre-5G)				
N7631C	5G NR (New Radio)				
		Current model ⁸	Description		
		N7609C	Global navigation satellite systems (GNSS)		
		N7620B	Pulse building		
		Current model ³	Description		
		N7605C	Real-time fading		
		N7608C	Custom modulation (Custom IQ and OFDM)		
		N7614C	Power amplifier test		
		N7621B	Multitone distortion		
		N7622C	IQ toolkit		

Software

- compatible instruments:
 - benchtop RF signal generators – CXG, EXG, MXG, VXG, PSG
 - wireless test sets – EXM E6640A, E6680A, E6681A
 - PXIe modular VSGs and transceivers – M9421A, M9410A/11A
 - AXIe arbitrary waveform generators – M8190A, M8195A,

Available instruments

- RF/MW benchtop signal generators:



PSG
MetrologyGrade
100 kHz to 44 GHz, 80 MHz BW
100 kHz to 67 GHz



VXG
Multi-Channel
1 MHz to 44 GHz, 2 GHz BW
9 kHz to 54 GHz, 2.5 GHz BW



MXG
Pure and Precise
9 kHz to 6 GHz, 160 MHz BW
9 kHz to 40 GHz



N5186A MXG
9 kHz to 8 GHz, 960 MHz BW
Multi-channel



EXG
Cost-effective
9 kHz to 6 GHz, 160 MHz BW
9 kHz to 40 GHz



CXG
Multi-Functional
9 kHz to 3/6 GHz, 120 MHz BW

Available instruments

- PXIe modular VSGs and transceivers:



M9381A



M9410A/11A



M9421A



M9415A

Available instruments

- wireless test sets – EXM E6640A, E6680A, E6681A



E6640A



E6681A



E6680A

Available instruments

- function / arbitrary waveform generators:



M8190A



E336xxA